



Original instructions



AVANTI

AVANTI SERVICE LIFT
Installation and Maintenance Manual
Model Service Lift OCTOPUS L80







Date of publication:

1st Edition: 09/2017

Revision 3: 15/10/2018

Manufacturer:

AVANTI Wind Systems A/S

Rønnevangs Allé 6

3400 Hillerød Denmark

P: +45 4824 9024

F: +45 4824 9124

E: info@avanti-online.com

I: www.avanti-online.com



Sales & Service:

Australia	Avanti Wind Systems PTY LTD	P: +61 (0) 3 9585 1852
China	Avanti Wind Systems	P: +86 21 5785 8811
Denmark	Avanti Wind Systems A/S	P: +45 4824 9024
Germany	Avanti Wind Systems GmbH	P: +49 (0) 41 21-7 88 85 – 0
Spain	Avanti Wind Systems SL	P: +34 976 149 524
UK	Avanti Wind Systems Limited	P: +44 0 1254 399923
USA	Avanti Wind Systems, Inc	P: +1 (262) 641-9101
India	Avanti Wind Systems, PL	P: +91 95 00 173 492
Brazil	Avanti Brazil Sistemas Eólicos. S.L.	P: +55 85 9 9955-0090

Manufactured Under Process Patent NO.8,499,896.

® Registered in Europe





Contents

	Page
1. Limited Warranty	5
2. Introduction	6
2.1 Observations	6
2.2 Symbols	6
2.3 Cautions	7
2.4 Terms and definitions	7
3. Installation	8
3.1 WTG integration requirements	8
3.2 Cautions	9
3.3 Service lift installation	9
3.4 Electrical connections on site	9
3.5 Travelling cable	9
3.6 Traction wire rope	10
3.7 Safety wire rope	10
3.8 Travelling cable pulley	10
3.9 Safe zone plates and top limit plate	11
3.10 Rescue guide	11
3.11 Inspection before first use	11
3.12 Disassembling	11
4. Maintenance	12
4.1 Recommended planning	12
4.2 Alternative planning	13
4.3 Cautions	13
4.4 Annual inspection	14
4.5 Repairs	16
4.6 Ordering spare parts	16
5. Appendix A: Regulation of overload limiter	17
6. Appendix B: Inspection checklist	19
7. Appendix C: Inspection Log Sheet	22
8. Appendix D: AVANTI lift anchor	23

1. Limited Warranty

Avanti Wind Systems A/S warrants that commencing from the date of shipment to the Customer and continuing for a period of the longer of 365 days thereafter, or the period set forth in the standard AVANTI warranty, the Product¹⁾ described in this Manual will be free from defects in material and workmanship under normal use and service when installed and operated in accordance with the provisions of this Manual.

This warranty is made only to the original user of the Product. The sole and exclusive remedy and the entire liability of Avanti under this limited warranty, shall be, at the option of Avanti, a replacement of the Product (including incidental and freight charges paid by the Customer) with a similar new or reconditioned Product of equivalent value, or a refund of the purchase price if the Product is returned to Avanti, freight and insurance prepaid. The obligations of Avanti are expressly conditioned upon return of the Product in strict accordance with the return procedures of Avanti.

This warranty does not apply if the Product (i) has been altered without the authorization of Avanti or its authorized representative; (ii) has not been installed, operated, repaired, or maintained in accordance with this Manual or other instructions from Avanti; (iii) has been subjected to abuse, neglect, casualty, or negligence; (iv) has been furnished by Avanti to Customer without charge; or (v) has been sold on an "AS-IS" basis.

Except as specifically set forth in this Limited Warranty,

ALL EXPRESS OR IMPLIED CONDITIONS, REPRESENTATIONS AND WARRANTIES, INCLUDING, BUT NOT LIMITED TO, ANY IMPLIED WARRANTY OR CONDITION OF MERCHANTABILITY, FITNESS FOR A PARTICULAR PURPOSE, NON-INFRINGEMENT, SATISFACTORY QUALITY, COURSE OF DEALING, LAW, USAGE OR TRADE PRACTICE ARE HEREBY EXCLUDED TO THE MAXIMUM EXTENT PERMITTED BY APPLICABLE LAW AND ARE EXPRESSLY DISCLAIMED BY AVANTI. IF, PURSUANT TO ANY APPLICABLE LAW, TO THE EXTENT AN IMPLIED WARRANTY CANNOT BE EXCLUDED AS PROVIDED IN THIS LIMITED WARRANTY, ANY IMPLIED WARRANTY IS LIMITED IN TIME TO THE SAME DURATION AS THE EXPRESS WARRANTY PERIOD SET FORTH ABOVE. BECAUSE SOME STATES DO NOT PERMIT LIMITATIONS ON THE DURATION OF IMPLIED WARRANTIES, THIS MAY NOT APPLY TO A GIVEN CUSTOMER. THIS LIMITED WARRANTY GIVES CUSTOMER SPECIFIC LEGAL RIGHTS, AND CUSTOMER MAY HAVE OTHER LEGAL RIGHTS UNDER APPLICABLE LAWS.

This disclaimer shall apply even if the express warranty fails of its essential purpose. In any cases of dispute the English original shall be taken as authoritative.

¹⁾ Avanti service lift ("Product")



2. Introduction

2.1 Observations

Only trained people may use this lift.

This manual must be available to staff at all times during installation, maintenance and operation. Additional copies are available from the manufacturer upon request. This manual, including, but not limited to, measurements, procedures, components, descriptions, instructions, recommendations and requirements, is subject to change without prior notice. Please check Avanti website/manuals for the latest revisions of the manuals. Any additional cost related to or arising from any changes in the manuals does not entitle Customer to any form of compensation or other legal remedies.



The pictures and sketches in this manual may not reflect the product aesthetics, colours, arrangement precisely. This has no impact on the function or safety.

2.2 Symbols

Symbol	Signal word	Meaning	Possible injury if not observed
--------	-------------	---------	---------------------------------

Safety instructions



DANGER!

IMMEDIATE or possibly imminent danger:

Death or severe injury!



DANGER!

IMMEDIATE or possibly imminent danger of hazardous voltage:

Death or severe injury!



CAUTION!

Potentially hazardous situation:

Light injury or material damage.

Additional instructions



ATTENTION!

Potentially dangerous situation:

Damage to equipment or workplace



IMPORTANT!

Useful tips for optimum working procedure

None

Order



Reference to written specification/documentation



2.3 Cautions

Use and daily inspection of the service lift shall only be performed by person who has gone through the relevant training associated with the Avanti service lift use and daily inspection and is in possession of a valid (non expired) certificate for the task. Installation and maintenance of the service lift shall only be performed by Certified technicians.

Personnel must be at least 18 years of age. The staff must be familiar with the relevant accident prevention instructions and must have received proper training in these.

Personnel are obliged to read and understand this Maintenance and Installation Manual.

Personnel shall wear PFPE (safety helmet, full body harness, shock absorber, lanyard and slider) at all times.

A copy of the Maintenance and Installation Manual must be handed out to the personnel and must always be available for reference.

If more than one person is entrusted with one of the above tasks, the employer shall appoint a supervisor in charge of the operation.

Electrical connection of the system must be made in accordance with EN 60204-1.

Self-locking nuts must be used at all times. The screw must extend from the nut by at least half of the thread diameter. The nut may not be used once it has become possible to loosen by hand! If any damage or faults are found during operation, or if circumstances arise which may jeopardize safety: immediately interrupt the work in progress and notify the supervisor or employer!

All tests/repairs of electrical installations may only be performed by a certified technician. All repairs to the traction, braking and supporting systems may only be performed by a certified technician.

If any supporting parts are repaired or replaced, the operational safety of the system must be tested and verified by a certified technician.

Only original fault-free parts may be used. Use of non-original parts will render the manufacturer's warranty void and any type approval invalid.

No modification, extension or reconstruction of the service lift is allowed without the manufacturer's prior written consent.

No warranty is provided against damage resulting from reconstruction or modification of equipment or use of non-original parts which are not approved by the manufacturer.

Service lift must be inspected by Certified technicians before first use.

Service lift must be inspected at least once a year by Certified technicians. In case of high operating frequency or severe conditions of use, more frequent inspection is required.

Service lift is designed for a lifetime of 20 years with an operating frequency of approximately 12.5 h/year (250 h in total).

Service lift may not be used by persons who are under the influence of alcohol or drugs which may jeopardize working safety.

The service lift shall not be used in case of fire in the tower.

Service lift shall ONLY be used when the turbine is not generating power.

All wind farm site specific rules must be followed. Service lift shall not be used during inclement weather, including wind speeds over 18 m/s.



Avoid injury – follow all instructions!



Owner must verify the need for third party service lift inspections with the local authority and comply with the standards specified.

2.4 Terms and definitions

Terms	Definitions
Certified technician	Person who has gone through the relevant training associated with the scheduled task from Avanti or from a certified trainer and is in possession of a valid (non expired) certificate for the task.
User	Person who has gone through the relevant training associated with the Avanti service lift use and daily inspection and is in possession of a valid (non expired) certificate for the task.
Manual descent	Action performed to descend the lift at a controlled speed without power supply by manually opening the hoist electromagnetic brake. (Also manual no-power descent)

3. Installation

3.1 WTG integration requirements

WTG component	General integration requirements	
Power supply	Power supply type	3 Phase + PE + N
	Voltage (50 Hz)	400 V ± 5 %
	Voltage (60 Hz)	400 V ± 5 %
	Fuses	16 A
	Protection	Acc. To EN 60204 – 1
	Location of power supply connection for service lift	Over mid tower's height
Platforms	Distance from rung center to platform outer edge for platforms over mid tower	1035 mm ¹⁾
	Distance from rung center to platform outer edge for platforms below mid tower	1105 mm ¹⁾
	Hole width	920 mm
	Minimum clearance around service lift	60 mm
Basement	Minimum height	600 mm ²⁾
Platform fences	Height	1.1 m
	Compliant to requirements of standard	EN 14122
	Fence door interlock system	Trapped key ⁴⁾ / Guardlocking ⁴⁾
	Max. total travel height	120 m (typical 140 m tower total height)
Safety ladder	Max. angle between ladder axis and vertical axis	± 3° ²⁾
	Max angle variance between ladder sections	± 1° ²⁾
	Max. distance between rung attachments	3360 mm ²⁾³⁾
	Forces capable to withstand by ladder brackets	Upon request to AVANTI
	Forces capable to withstand by ladder sections	Upon request to AVANTI
	Ladder width for Octopus	490 mm ²⁾
	Standard stile profile dimensions	74 x 25 mm ²⁾
	Rung dimensions	29 x 27 mm ²⁾
Top beam	Forces capable to withstand by top beam	Upon request to AVANTI
	Max. thickness of top beam for 2 Tn shackles (C shape)	20 mm
	Min. distance between top platform and top beam shackle holes	3000 mm ²⁾

¹⁾ Depending of travel path, dimension may need to be larger in order to avoid collisions of travelling cable pulley with platforms.

²⁾ Other dimensions are possible upon request and design verification by AVANTI.

³⁾ In case of single rung brackets: 2240 mm. between the centers of brackets.
In case of double rung brackets: 3360 mm. between the centers of brackets.



⁴⁾Note: Optional feature.

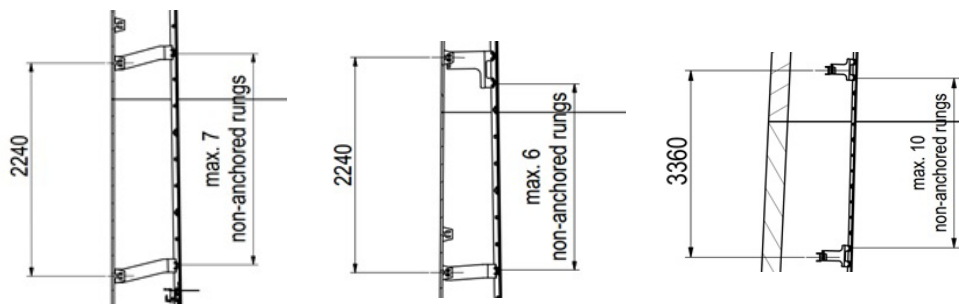

A gap of 2 mm is demanded from each side of the fishplate to the ladder.

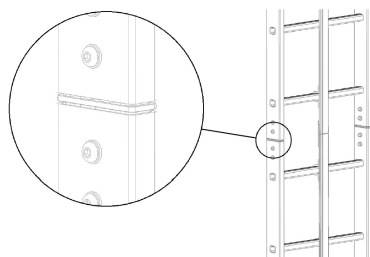

The WTG manufacturer shall put in place any other means necessary to ensure the safe use of the service lift according to AVANTI recommendations and its own risk assessment for the integration that shall include items which are not under AVANTI's scope.

The Octopus service lift is designed for a lifetime of 20 years with a frequency of use of approximately 12.5 h / year or 250 h during life. In case frequency of use is higher, service, inspections and replacement of components might be more often, according to the replacement criteria stated in the maintenance instructions.



3.2 Cautions

Prior to installation, ensure that:

- Building sections involved will be able to withstand the service lift loads.
- All parts are available and fully functional.
- Travel zone is protected by fences at each platform.
- Walking way surfaces are dry and not slippery.

The customer must define the maximum allowable wind speed ensuring safe installation.

During installation tasks, personnel shall:

- Wear at least the following PFPE: fall arrest equipment if falling height is higher than 2 m, hand gloves, helmet, safety glasses, working gear.
- Use a hand winch attachable to the ladder when elevating heavy weights.
- Use a cable clamp or grip when lowering traction and safety wire ropes.
- Not work at different levels if tasks involve risk of falling objects.

Installation shall be performed by certified technicians. At the end of the workday security measures must be taken to put the service lift out of service and make the ladder accessible.

3.3 Service lift installation



The WTG manufacturer shall provide 3D drawings to ensure that installation of lift on ladder is possible.

3.3.1 After tower erection

The service lift is installed on to the ladder after tower erection.

1. Mount safe zone plates, top limit plate and rest platforms on ladder.
2. Fit the nuts and bolts to the shackles, and lock with cotter pins.
3. Mount traction and safety wire ropes (Ø8 mm) using the shackles supplied for the top beam at the top of the tower.
4. Follow instructions from chapter “Electrical connections on-site” onwards.

3.3.2 Before tower erection

Alternatively, the service lift can be installed on to the ladder before tower erection. With the tower section lying horizontally:

1. Mount safe zone plates, final limit activation plates and rest platforms on ladder.
2. Fit the nuts and bolts to the shackles, and lock with cotter pins.
3. Mount traction and safety wire ropes (Ø8 mm) using the shackles supplied for the top beam at the top of the tower.

4. Attach coiled wire ropes to top beam by means of cable strips to prevent them from moving during transport of tower section.
5. Position service lift on ladder at bottom platform, by means of a crane and the lifting eyes.
6. Mount fixing set for transport to prevent lift from moving during transport of tower section.
7. The tower sections shall be transported to the wind farm.
8. Pre-tension the 8 mm wire ropes by acting manually the motor of the hoist with a wrench, to be able to free the fasten kit after tower erection.
9. After tower erection takes place, follow instructions from chapter “Electrical connections on-site” onwards.

3.4 Electrical connections on site



Before making any connection, disconnect any power supply to the service lift and the fence interlock system; and verify with WTG responsible.

The electrical connection of the traction hoist must be made in accordance with EN 60204-1. The power supply must be protected by a fuse and against indirect contacts according to local regulations. Verify that the rated grid and motor voltages are identical.



Electrical system shall be properly insulated.

3.5 Travelling cable

1. Install power supply socket over mid tower's height platform; and install a cable relief on the platform fence.

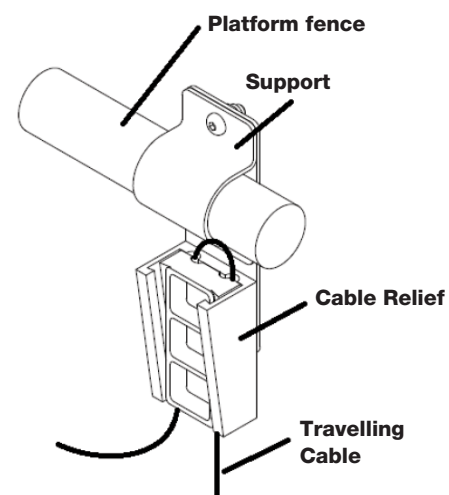



2. Feed travelling cable through the cable relief, without plugging it to power supply socket!
3. Uncoil the cable to the bottom platform.



The travelling cable must be evenly uncoiled to prevent looping.

4. Plug travelling cable outlet directly to service lift (provisional connection).
5. Plug travelling cable inlet to power supply socket over mid tower's height.

3.6 Traction wire rope

1. Uncoil both wire ropes to the bottom of the WTG.



All wire ropes must be evenly uncoiled to prevent looping.

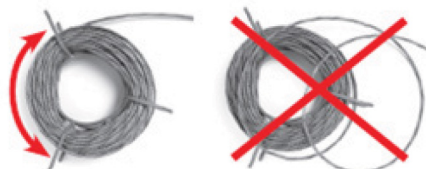

2. Check that traction and safety wire ropes are not crossed.
3. Feed the traction wire rope through the roof into the traction hoist inlet opening.
4. Push the UP button of cabin control box to continue feeding wire rope through until the hoist starts pulling.
5. Open maintenance cover and feed wire rope through guide bushing of service lift.
6. Feed through guide bushing of travelling cable pulley.
7. Feed through the platform hole.
8. Attach an 11 kg counterweight to it at least 600 mm below the bottom platform.
9. Coil and fasten remaining wire rope with at least 3 cable ties.
10. Check that wire rope and counterweight are able to rotate freely.

3.7 Safety wire rope

1. Feed the safety wire rope through the roof into the fall arrest device inlet opening.
2. Pull the wire rope through while turning the fall arrest device release lever clockwise.
3. Open maintenance cover and feed wire rope through guide bushing of service lift.
4. Feed through guide bushing of travelling cable pulley.
5. Feed through the platform hole.
6. Feed the wire rope through the compression spring.

7. Fasten cable ties to the compression spring, and adjust them to compress the spring.
8. Pre-tension the safety wire rope by hand as much as possible and fasten the wire lock.
9. Cut the cable ties that keep the spring compressed. The spring will apply a tension of approximately 40 kg to the safety wire rope.

3.8 Travelling cable pulley

1. Turn the override key of bottom obstruction device switch.
2. Manually descend service lift until rubber feet reach bottom platform floor.
3. Unplug travelling cable inlet from power supply socket over mid tower's height, leaving it attached with the cable relief.
4. Unplug travelling cable outlet from service lift socket.
5. Demount plug head from cable and adjust cable length by cutting off excess.
6. Feed cable through pulley until it is positioned 2 cm. from service lift wire rope bushings.
7. Feed cable through cable relief, mount plug and plug it back to service lift. Attach the cable to the lift between the cable relief and the panel inlet by means of plastic strips every 300 mm.
8. Plug travelling cable inlet from power supply socket over mid tower's height.

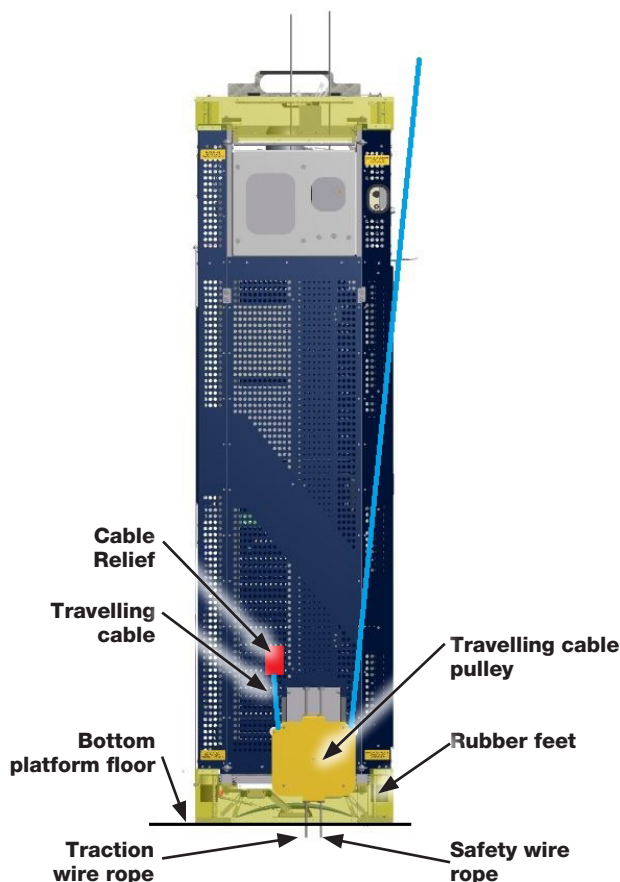



3.9 Safe zone plates and top limit plate

Adjust the final position of the safe zone plate on each platform, so that the service lift floor is levelled with the platform floor when it stops.

Adjust the final position of the top limit plate so that the service lift floor is levelled with the top platform floor when it stops.

3.10 Rescue guide

Place the “Rescue Guide” in a visible place on the bottom platform, preferably near the location of the rescue pendant control.

3.11 Inspection before first use

A certified technician must carry out an inspection before first use following the Annual inspection procedure and filling in the Inspection checklist.



Inspection shall only be carried out by certified technicians, following the Annual inspection procedure.



And filling in the Inspection checklist for future possible reference.



Owner must ensure that the results of this inspection before first use are logged in the Operation log sheet.

3.12 Disassembling

In accordance with local authority regulations disassemble in reverse order and dispose.

4. Maintenance

All the inspections / maintenance operations (periodical or extraordinary) must be logged in the appropriate Inspection Appendix.

All inspections and service tasks made to the hoist and fall arrest device must be carried out by certified technicians.

The relevant maintenance instructions are provided to each person during the training.

4.1 Recommended planning

Avanti recommends the following maintenance planning:

Frequency	Performed by	Components
Daily	User	Overall / Travel zone
		Control and safety devices
		Fall arrest device
Annually	Certified Technician	Overall / Travel zone
		Control and safety devices
		Cabin
		Traction hoist
		Fall arrest device
		Overload limiter
		Traction and safety wire ropes
		Guiding system
		Electrical system
		Information signs and documents
		Doors and hatches
		Cabin control box
		Safety switches
		Interlock system ¹⁾
Platforms		
Every two years	Certified Technician	Fall arrest device
Every five years or 50 hours (whatever occurs first)	Certified Technician	Traction hoist
Every 20 years or 250 hours of operation (whatever occurs first)	At Avanti Workshop	Traction hoist
		Fall arrest device



¹⁾Note: Optional feature.

4.2 Alternative planning

Owners who strictly follow the maintenance program and the daily inspections, and can document it could decide with taking over the responsibility as well to provide the following alternative planning:

Frequency	Performed by	Components
Daily	User	Overall / Travel zone
		Control and safety devices
		Fall arrest device
Annually	Certified Technician	Overall / Travel zone
		Control and safety devices
		Cabin
		Traction hoist
		Fall arrest device
		Overload limiter
		Traction and safety wire ropes
		Guiding system
		Electrical system
		Information signs and documents
		Doors and hatches
		Cabin control box
		Safety switches
		Interlock system ¹⁾
Platforms		
Every ten years or every 125 hours of operation (whatever occurs first)	Certified Technician	Traction hoist
		Fall arrest device
Every 20 years or 250 hours of operation (whatever occurs first)	At Avanti Workshop	Traction hoist
		Fall arrest device



¹⁾Note: Optional feature.

4.3 Cautions

Before any maintenance task, ensure that walking way surfaces are dry and not slippery.

Before any maintenance operation, check that the service lift is properly out of service.

In case of a fault, do not use the service lift until it is solved. If required secure workplace.

Entire system shall be tested by a certified technician at least once a year, nevertheless local regulations may require more frequent inspections instead of every year.

During maintenance tasks, personnel shall:

- Wear at least the following PFPE: fall arrest equipment (when falling height is more than 2 m), hand gloves, helmet, safety glasses and working gear.
- Place cabin at bottom platform and disconnect power supply.
- Use an electricity measuring tool when performing inspection of electrical components.

- Use a hand winch attachable to the ladder when handling big/ heavy loads and shall be performed at least by 2 persons.
- Panel parts shall be removed to facilitate access to confined spaces.
- Use a cable grip when replacing travelling cable.
- Keep cabin doors closed when using a 3-step ladder.



Only certified technicians shall perform electrical installation tasks.



When plugging the service lift to the power supply, ensure that supply phases are correct!



4.4 Annual inspection

Have the entire system tested by a certified technician at least once a year, especially the traction hoist and the fall arrest device. However, it may be required more frequently depending on use and the conditions of use and operation. The traction hoist and fall arrest device must be inspected according to intervals included in the sections 4.1 or 4.2 tables (see above). Hour counter is found in the main control box.



A certified technician must carry out the annual inspection following the appropriate Inspection Appendix.



Owner must ensure that the results of all annual and extraordinary inspections are logged in the appropriate Inspection Appendix.



In case of replacement of hoist, Fall Arrest Device and/or 8 mm. wire ropes, the operation/s and the related total hours of use of this/these component/s, must be logged in the appropriate Inspection Appendix.

4.4.1 Cabin

Inspect the cabin structure, joints, attachments and accessories.

4.4.2 Traction hoist

The traction hoist shall be maintained according to maintenance planning (please see sections 4.1 or 4.2). Relevant maintenance instructions are provided to each person during the training.

These maintenance inspections must be only carried out by a certified technician.

4.4.3 Fall arrest device

The fall arrest device shall be maintained according to maintenance planning (please see sections 4.1 or 4.2). Relevant maintenance instructions are provided to each person during the training.



If fall arrest device has engaged due to a dynamic fall, a certified technician must verify the safety of the fall arrest device, the wire rope, and wire rope fastenings.



After FAD has engaged, if the FAD damper has moved downwards, the FAD unit must be replaced by a certified technician.

4.4.4 Traction and safety wire ropes

Perform the following inspections and adjust if necessary:

1. Inspect all the wire ropes along their entire length.
2. Pay special attention to the wire rope ends, parts of the wire ropes running over sheaves and wire ropes under frictional wear by external components.
3. When inspecting the wire ropes, consider the following points:

- type and number of wire breaks,
 - position and time sequence of wire breaks,
 - decrease of the wire rope diameter during operation,
 - corrosion, abrasion, deformation,
 - influence of heat, and
 - operating time.
4. Check that the traction, and safety wire ropes are fed correctly around the 2 wire rope guide wheels.
 5. Check that the wire rope ends are coiled separately under the bottom platform and tied with at least 3 cable ties.
 6. Check that the compression spring on the safety wire rope is correctly installed and that the wire rope locks are fastened.
 7. Check that the counterweight on the traction wire rope is properly fastened. The traction wire rope coil and counterweight shall be able to rotate freely. Do not attach it to a fixed part.



Record any visible change of the condition of the wire rope on the "Operation log sheet", and monitor closely; throughout time.

4.4.4.1 Cleaning

1. Open the maintenance cover to access the wire ropes from inside the service lift.
2. Use a cloth to wipe off the old grease from the wire ropes.
3. Close the maintenance cover and ascend the service lift 1 or 2 m.
4. Repeat steps 1 to 3 until the entire length of the wire ropes is clean.



Always keep the traction, safety and guiding wire ropes clean and slightly greasy. Only use mechanical means to clean the dirty wire ropes, i.e. a cloth or a hand brush. Do not use solvents or other detergents.

4.4.4.2 Lubrication

If the distance between platforms is more than 20 m perform the following procedure:

1. Ascend the service lift 20 m.
2. Open the maintenance cover.
3. With a spray can, apply lubricant on the wire ropes.
4. Close the maintenance cover and ascend the service lift 1 or 2 m.
5. Repeat steps 1 to 4 until the entire length of the wire ropes is lubricated.
6. Finally, perform two complete ascends and descends in order to distribute the new lubricant evenly along the wire ropes.

If the distance between platforms is equal or less than 20 m perform the following procedure:

1. A first person ascends in the service lift several meters so that the wire ropes are accessible from the platform.





2. From the platform and with a spray can, a second person applies lubricant on the wire ropes.
3. Both persons ascend in the service lift to the next platform.
4. One person egresses to the next platform.
5. Repeat steps 1 to 4 on each platform until the entire length of the wire ropes is lubricated.
6. Perform two complete ascends and descends in order to distribute the new lubricant evenly along the wire ropes.



Only use specialised wire rope lubricants. Do not use lubricants based on lithium soap grease or bitumen. Do not use disulphide containing lubricants like Molycote®. Apply lubricant using a spray can, brush, drip applicator or pressurized device. Pay special attention to sections of the wire rope where dehydration or denaturation of the lubricant can be seen.



Re-lubricate the wire ropes before they show signs of corrosion or run dry.

- A poor lubrication leads to corrosion and to a quick wear of components.
- An excessive lubrication leads to dirt agglomeration on the wire rope surface. As a result, this can lead to quick wear of wire rope, sheaves and drum.
- A correct lubrication keeps the efficiency factor of the wire rope, protects against corrosion, helps to elongate their lifetime significantly and ensures a safe operation.

4.4.4.3 Measuring of the wire rope diameter



When measuring the diameter of the wire ropes, use a digital calliper with broad measuring faces.



In general, measure the diameter of the wire rope at each WTG tower platform, and under the service lift, where the wire rope is less loaded. Specifically, if a wire rope wear is detected, measure on the affected area.



Rotate the calliper around the wire rope to measure the minimum and maximum wire rope diameter at each measurement point.

4.4.4.4 Discard criteria



The discard criteria of the wire ropes should be based on ISO 4309: Cranes - Wire ropes - Care and Maintenance, inspection and discard.



Determine and eliminate the cause before installing a new wire rope.

AVANTI recommends to replace the traction and safety wire ropes after 250 hours of operation corresponding with the refurbishment of the traction hoist and fall arrest device. Please check with your local authority regulations if it's mandatory in your case.

Check and replace the respective wire rope(s) if one of the following defects is found:

- For traction and safety wire ropes, there are more than one 4-wire strand break on a wire rope length of 250 mm.



- If there is severe corrosion on the surface or the inside.
- If there is heat damage, evident by the wire rope colour.
- For traction and safety wire ropes, if the wire rope diameter is less than 7,6 mm.
- If there is damage on the wire rope surface (see following figures for most common examples of wire rope damage).



Kinks resulting from counterweight of traction wire rope not being able to rotate freely.

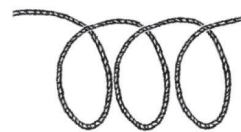

Wire strap/loop, which cannot be unwound



Loop knot forming when a wire loop is pulled tight



Bends resulting from inappropriate treatment (e.g. securing the load with the wire)



Damage resulting from crushing, squeezing, running over, etc.



Wire bags



Loop formation





4.4.5 Guiding system

Perform the following inspections and adjust if necessary:

1. Check that the guiding ladder does not show breaks, damages or corrosion, that is correctly installed and that the locks and fixes are properly fastened.
2. Check that outer surface of guiding rollers is uniform and free of damage, and are properly installed. Check if wear of surface of guiding rollers is not be bigger than 1 mm.

4.4.6 Electrical cables

Check and replace the power supply and control cables if the cable jacket or cable connections are damaged.

4.4.7 Overload check and adjustment

Annual test:

Test switches and perform overload test as specified in the "Regulation of overload limiter" Appendix.

4.4.8 Information signs and documents

Verify availability and legibility of all data plates and information signs. Replace missing or illegible plates and signs!

4.5 Repairs

Repairs to traction hoist equipment must ONLY be performed by AVANTI, and only using original spare parts.

If the gearbox oil needs to be replaced, use one of the lubricants specified below, corresponding to the temperature range in which the traction hoist equipment is used.

- Amount required: 1,5 l
- Traction hoist: M508
- Oil: Mobil SHC 632.

Each oil has to be verified by AVANTI.

4.6 Ordering spare parts

Only use original parts.

Spare part lists are available from AVANTI. Please indicate lift model when requesting a spare part list.

Appendix A: Regulation of overload limiter

Verification and/or adjustment of the overload device on the service lift can only be done by a certified technician, who must have been instructed by AVANTI to perform this task.



Avoid injury by strictly following the instructions!

Required tools/material:

- Security Torx 40.
- Test weights for applying the test load.

To modify the lifting load limit:

1. Insert the overload adjustment tool in the adjustment screw through the hole as shown in the figure.

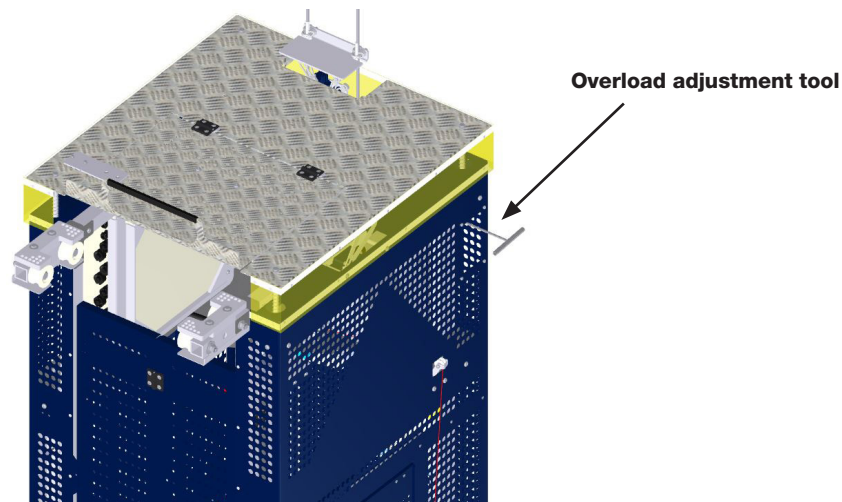

2. Turn the tool clockwise to increase the lifting load limit.
3. Turn the tool counter-clockwise to decrease the lifting load limit.



One turn on the adjustment screw represents a change of approximately 40 Kg of the lifting load limit.

To adjust the lifting load limit proceed as follows:

Travel distance	Setup load L80 (kg)
115 to 120 m	360
105 to 115 m	355
95 to 105 m	350
85 to 95 m	345
75 to 85 m	345
65 to 75 m	340
55 to 65 m	335



The overload limiter complies with EN 1808 8.3.5.5 since it will trigger before reaching a load of 1,25 times the working load limit of the hoist. In case that a third party inspector requests this test to be done, the load to be introduced in the cabin is as follows.

Overload test load = WLL hoist x 1,25 – Weight of lift
-Tolerance overload device (20 kg).

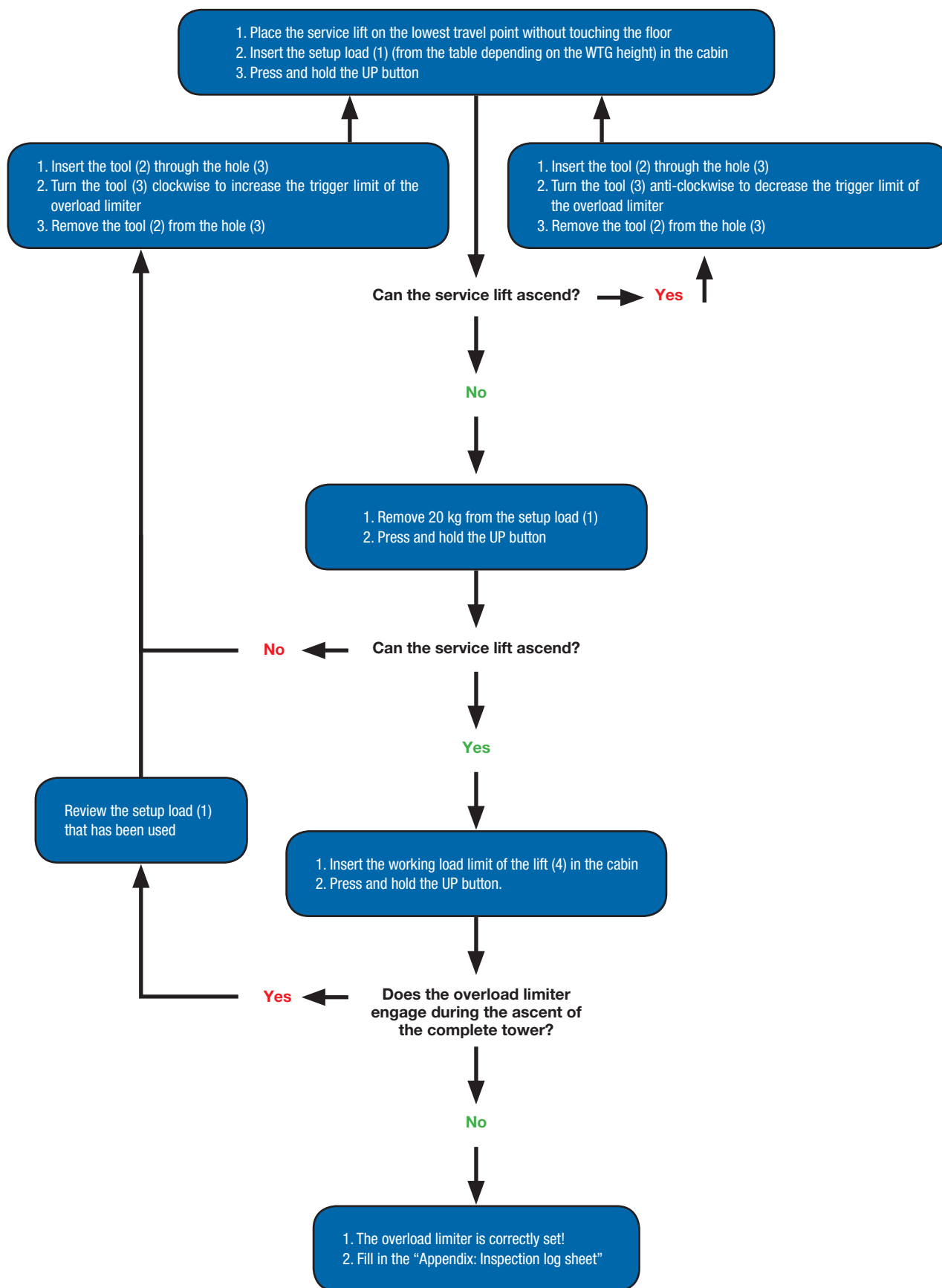



Appendix D: AVANTI lift anchor

D.1 Caution

AVANTI LIFT ANCHOR is an anchor point used for protection against falls from heights intended for use with a full body harness approved according to EN 361 or Z359.1:2007 as applicable. Connection to the LIFT ANCHOR is only allowed by using self-closing connectors according to EN 362 or Z359.1:2007 as applicable.

Use in connection with other equipment than specified, may be potentially dangerous. User shall be equipped with a means of limiting the maximum dynamic forces exerted on the user during the arrest of a fall to a maximum of 6kN. In case of doubt, please contact AVANTI.

The maximum load that can be transmitted in service from the anchor device to the structure is 22.2 kN in $\pm 15^\circ$ vertical direction. The maximum deflection of the anchor point that can occur in service is 10mm.

AVANTI LIFT ANCHOR is tested and approved only to be mounted on AVANTI lifts. This manual always needs to be represented in language of sale and provided for use by all technicians. Activities at height are dangerous and may lead to severe injury or even death.

Gaining an adequate apprenticeship in appropriate techniques and methods of protection is important and is your own responsibility.

Users are obliged to read and understand this User Manual. Further they need to be properly equipped and instructed with the use of the necessary fall arrest equipment and emergency procedures in case of injury or sudden illness.

Users going to install AVANTI LIFT ANCHOR need to be familiar with the installation section of this manual. It's essential to the safety, that the user always attach the energy absorber as high as possible above his/her position, to minimize the fall distance most possible in case of a fall.

The position of the anchor point is crucial for fall arrest – the height of the fall, elongation of lanyard and energy absorber or pendulum movement of the user should be considered in order to minimize the risk of impact in obstacles in case of a fall. It's prohibited for the user to do many modifications or use non original Avanti components when assembling AVANTI LIFT ANCHOR.

Re-use of demounted AVANTI LIFT ANCHORS or parts is not allowed. Any changes or other uses beyond this manual are strictly forbidden.

Any changes or other uses beyond this manual are strictly forbidden. This documentation must be kept in the service lift for the purpose of subsequent examinations of the anchor device.

D.2 Danger

The AVANTI LIFT ANCHOR is for the use of one person only. It is strictly forbidden to carry out work if the person is in unfit mental or physical condition. Climbing and working under the influence of alcohol, drugs or any medication which can interfere with the safety are also much prohibited.

If there are any doubts to the safety of the AVANTI LIFT ANCHOR, or it isn't properly fixed, deformed or damaged with cracks or similar incompatible harms it may never be used – Please contact the manufacturer immediately. In case of corrosion the anchor immediately needs to be removed.

Observations:

- Only to be used by instructed workers! Instructed workers must be aware, instructed and prepared to utilize site rescue plans.
- Only to be used for preventing vertical fall!
- Only to be used for fall arrest, not to hoist or hang in goods or similar! Before attaching in the ANCHOR the user needs to check it is sitting fixed and screws are sitting tight and proper.
- If AVANTI LIFT ANCHOR has arrested a fall it may never be used again. Part must be removed from service immediately.





D.3 Marking

Marking on Lift Anchor plate:

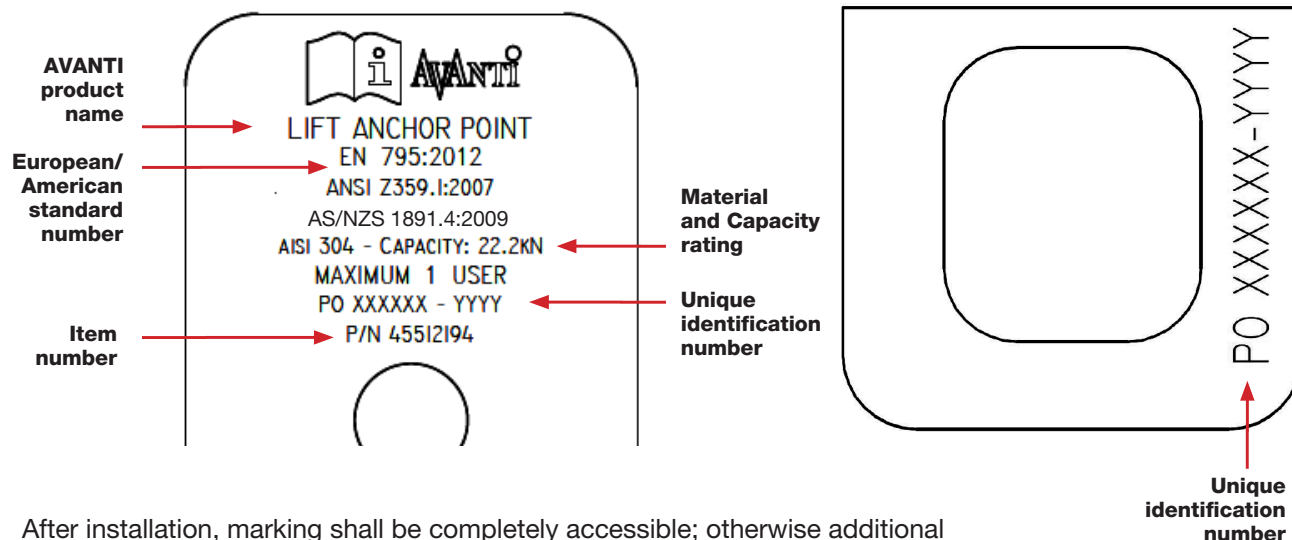

After installation, marking shall be completely accessible; otherwise additional marking near the anchor device will be necessary.

D.4 Installation

The installation must be performed by a certified technician following the instructions of this manual.

AVANTI LIFT ANCHOR is tested and approved only to be installed on AVANTI lift. AVANTI LIFT ANCHOR made from AISI 304 Steel has to be screwed with two bolts DIN 933 A2-70 M12 mm, 4 washers DIN 125A A4 and self locking nuts DIN 985 A4 M12. In case of doubt, please contact AVANTI.

Before installing the AVANTI LIFT ANCHOR in heights, assure to be proper secured against fall from height by using relevant fall arrest equipment.

AVANTI LIFT ANCHOR:

1. Fix the anchor point to the structure using the supplied hardware as shown in the picture below.
2. Torque the nuts with 15 N·m (11 lb·ft).
3. Make sure the Anchor is fully seated and properly tightened.
4. Fill in "Installation form".
5. Carry out yearly inspection by following the procedure in the section "Inspection".

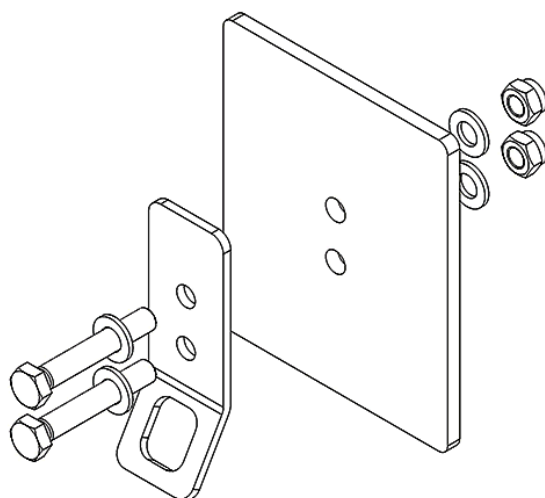

D.5 Inspection

After installation:

An inspection must be carried out by a certified technician following the inspection form in this manual.

Before use:

Each time using the AVANTI LIFT ANCHOR the user inspects the ANCHOR visual and manually by twisting / pulling. Check the parts are properly fixed and free of deformities, damages, cracks or similar unacceptable defects.

Periodical examination:

A periodic examination at least every 12 month is essential for the safety of the AVANTI LIFT ANCHOR. The examination must be performed by a certified technician following the inspection form in this manual.

For the AVANTI LIFT ANCHOR the certified technician only needs to be trained in any metallic component covered by the European/American standard norms for fall arrest equipment.

D.6 Inspection form

PPE Anchor:	Manufacturer:	Avanti
	Type / Model:	Lift Anchor
	Identification no.:	
Fixing structure:	Lift serial no.:	
	Lift model:	
	Wind farm / WTG no.:	
Installed by:		
Installation company:		

	OK	not OK
1. Lift structure does not show any deterioration.		
2. Anchor locking screws are fully inserted and tightened with 15 N·m.		
3. Anchor does not show cracks, deformities, corrosion or other damages.		
4. Anchor installed on the lift structure according to the instructions.		
5. Anchor marking is clearly readable.		

Is the Anchor in good condition to be used?

Yes	No (Replace)
<input type="checkbox"/>	<input type="checkbox"/>

Signature of competent:

Name of competent in

capital letters:

Date:

If the AVANTI LIFT ANCHOR is found not OK, it must be removed / replaced by a new AVANTI LIFT ANCHOR! The result of the periodic examination must be recorded in the Registration form of anchor.



AUSTRALIA

Avanti Wind Systems PTY LTD
Unit 7 / 109 Tulip Street, Cheltenham Melbourne VIC 3192
P: +61 (0) 3 9585 1852

CHINA

Avanti Wind Systems
Building 4, No, 518,
Gangde Road, XiaokunshanTown
Songjiang District, 201614 Shanghai
P: +86 21 5785 8811 · F: +86 21 5785 8815

DENMARK

Avanti Wind Systems A/S
Rønnevangs Allé 6 · DK-3400 Hillerød
P: +45 4824 9024 · F: +45 4824 9124

GERMANY

Avanti Wind Systems GmbH
Max-Planck-Str. 10 25335 Elmshorn
P: +49 (0) 41 21-7 88 85 – 0 · F: +49 (0) 41 21- 7 88 85-20

SPAIN

Avanti Wind Systems SL · Poligono Industrial Centrovía
Calle Los Angeles No 88 nave 1 · 50198 La Muela
P: +34 976 149524 · F: +34 976 149508

UK

Avanti Wind Systems Limited
Unit 2, Cunliffe Court Clayton-Le-Moors
Accrington BB5 5JG
P: +44 0 1254 399923

USA

Avanti Wind Systems, Inc.
11311 West Forest Home Ave. Franklin, Wisconsin 53132
P: +1 (262) 641-9101 · F: +1 (262) 641-9161

INDIA

Avanti Wind Systems India (P) Ltd.
Old No. 28, New No. 41,
Vellala Street, Aiyambakkam
Chennai 600095 · Tamil Nadu
P: +91 95 00 173 492

BRAZIL

Avanti Brasil Sistema Eólicos LTDA.
Rua João Paulo II, 131 Autódromo
Eusébio, Ceará 61760-000
P: +55 85 9 9955-0090

I: www.avanti-online.com · E: info@avanti-online.com