



## Original instructions



# AVANTI

## AVANTI SERVICE LIFT

User Manual

Model Service Lift PEGASUS L03 BUCKET TYPE





**Date of publication:**

1st Edition: 04/19

Revision 2: 18/07/19

**Manufacturer:**

Avanti Wind Systems, S.L.

Calle Ángeles (Los), Num. 88

Pol. Industrial Centrovía

50198 Muela (La) - (Zaragoza) - Spain

P: +34 976 149524

F: +34 976 149508

E: [info@avanti-online.com](mailto:info@avanti-online.com)

I: [www.avanti-online.com](http://www.avanti-online.com)



Manufactured Under Process Patent NO.8,499,896.  
© Registered in Europe

**Sales & Service:**  
[avanti-online.com/contact](http://avanti-online.com/contact)





# Contents

	Page
<b>1 Limited Warranty</b> .....	<b>7</b>
<b>2 Introduction</b> .....	<b>8</b>
2.1 Observations .....	8
2.2 Symbols .....	8
2.3 Cautions .....	9
2.4 Terms and definitions .....	9
<b>3 Description</b> .....	<b>10</b>
3.1 Purpose .....	10
3.2 Scope .....	10
3.3 Exclusions .....	10
3.4 Technical specifications .....	11
3.5 General arrangement of service lift inside a generic WTG .....	12
3.6 Service lift overview .....	13
3.6.1 Bucket type .....	13
3.7 Service lift dimensions .....	14
3.7.1 Bucket type .....	14
3.8 Main frame .....	15
3.9 Controls .....	16
3.9.1 Bottom platform control box .....	16
3.9.2 Cabin control box .....	16
3.9.3 Mid tower junction box .....	17
3.9.4 Top platform control box .....	17
3.10 Service lift doors .....	18
3.10.1 Pegasus L03 double door .....	18
3.11 Front windows .....	19
3.12 Top hatch .....	19
3.13 Bottom hatches .....	20
3.14 Top obstruction device .....	20
3.15 Top limit switch .....	21
3.16 Bottom obstruction device .....	21
3.16.1 With bottom limit switch configuration .....	21
3.17 Emergency limit switch .....	21
3.18 Top and bottom mechanical stop .....	22
3.19 Traction system .....	23
3.20 Guiding and anti-derailment system .....	23
3.21 Overload limiter .....	24
3.22 Manual descent system .....	24
3.23 Rest platforms .....	24
3.24 Anchor points for PPE .....	24
3.25 Information signs and documents .....	25
3.26 Cabin light .....	25
3.27 Warning lights .....	25
3.28 Platform fences .....	25
<b>4. Instructions for use</b> .....	<b>26</b>
4.1 Daily inspection .....	26
4.1.1 Travel zone .....	26
4.1.2 Visual inspection .....	26
4.1.3 Functional inspection .....	26
4.2 Cautions .....	27
4.3 Prohibited uses .....	27
4.4 Operation from inside the cabin .....	27
4.5 Operation from bottom platform .....	27
4.6 Operation from top platform .....	27
4.7 Landing alignment .....	27





4.8	Entering and exiting the cabin	28
4.8.1	Pegasus L03 Bucket type	28
4.8.2	Top / Bottom hatch	28
4.9	Emergency stop button	28
4.10	Manual descent	29
4.11	Rest platforms	29
4.12	Service ladder	29
4.13	Troubleshooting	30
4.14	Out of service	31
<b>Appendix A: Daily inspection</b>		<b>32</b>
<b>Appendix B: AVANTI lift anchor point</b>		<b>34</b>

# 1. Limited Warranty

Avanti Wind Systems, S.L. warrants that commencing from the date of shipment to the Customer and continuing for a period of 365 days thereafter, or the period set forth in the standard AVANTI warranty, the Product<sup>1)</sup> described in this Manual will be free from defects in material and workmanship under normal use and service when installed and operated in accordance with the provisions of this Manual.

This warranty is made only to the original user of the Product. The sole and exclusive remedy and the entire liability of AVANTI under this limited warranty, shall be, at the option of AVANTI, a replacement of the Product (including incidental and freight charges paid by the Customer) with a similar new or reconditioned Product of equivalent value, or a refund of the purchase price if the Product is returned to AVANTI, freight and insurance prepaid. The obligations of AVANTI are expressly conditioned upon return of the Product in strict accordance with the return procedures of AVANTI.

This warranty does not apply if the Product (i) has been altered without the authorization of AVANTI or its authorized representative; (ii) has not been installed, operated, repaired, or maintained in accordance with this Manual or other instructions from AVANTI; (iii) has been subjected to abuse, neglect, casualty, or negligence; (iv) has been furnished by AVANTI to Customer without charge; or (v) has been sold on an "AS-IS" basis.

Except as specifically set forth in this Limited Warranty,

ALL EXPRESS OR IMPLIED CONDITIONS, REPRESENTATIONS AND WARRANTIES, INCLUDING, BUT NOT LIMITED TO, ANY IMPLIED WARRANTY OR CONDITION OF MERCHANTABILITY, FITNESS FOR A PARTICULAR PURPOSE, NON-INFRINGEMENT, SATISFACTORY QUALITY, COURSE OF DEALING, LAW, USAGE OR TRADE PRACTICE ARE HEREBY EXCLUDED TO THE MAXIMUM EXTENT PERMITTED BY APPLICABLE LAW AND ARE EXPRESSLY DISCLAIMED BY AVANTI. IF, PURSUANT TO ANY APPLICABLE LAW, TO THE EXTENT AN IMPLIED WARRANTY CANNOT BE EXCLUDED AS PROVIDED IN THIS LIMITED WARRANTY, ANY IMPLIED WARRANTY IS LIMITED IN TIME TO THE SAME DURATION AS THE EXPRESS WARRANTY PERIOD SET FORTH ABOVE. BECAUSE SOME STATES DO NOT PERMIT LIMITATIONS ON THE DURATION OF IMPLIED WARRANTIES, THIS MAY NOT APPLY TO A GIVEN CUSTOMER. THIS LIMITED WARRANTY GIVES CUSTOMER SPECIFIC LEGAL RIGHTS, AND CUSTOMER MAY HAVE OTHER LEGAL RIGHTS UNDER APPLICABLE LAWS.

This disclaimer shall apply even if the express warranty fails of its essential purpose.

In any cases of dispute the English original shall be taken as authoritative.

\* Avanti service lift ("Product")

## 2. Introduction

### 2.1 Observations

**Only trained people may use this lift.**

This manual must be available to staff at all times during installation, maintenance and operation.

Additional copies are available from the manufacturer upon request.

This manual, including, but not limited to, measurements, procedures, components, descriptions, instructions, recommendations and requirements, is subject to change without prior notice. Please check Avanti website/manuals for the latest revisions of the manuals. Any additional cost related to or arising from any changes in the manuals does not entitle Customer to any form of compensation or other legal remedies.



*The pictures and sketches in this manual may not reflect the product aesthetics, colours, arrangement precisely. This has no impact on the function or safety.*

### 2.2 Symbols

Symbol	Signal word	Meaning	Possible injury if not observed
--------	-------------	---------	---------------------------------

#### Safety instructions



**DANGER!**

IMMEDIATE or possibly imminent danger:

Death or severe injury!



**DANGER!**

IMMEDIATE or possibly imminent danger of hazardous voltage:

Death or severe injury!



**CAUTION!**

Potentially hazardous situation:

Light injury or material damage.

#### Additional instructions



**ATTENTION!**

Potentially dangerous situation:

Damage to equipment or workplace



**IMPORTANT!**

Useful tips for optimum working procedure

None



Reference to written specification/documentation

## 2.3 Cautions

Use and daily inspection of the service lift shall only be performed by AVANTI or personnel authorised by AVANTI, hired by the employer for the job at hand. Installation and maintenance of the service lift shall only be performed by AVANTI or qualified personnel authorised by AVANTI, hired by the employer for the job at hand. Additionally, these tasks may be performed by qualified personnel authorised by a trainer authorised by AVANTI.

The personnel must be at least 18 years of age. The staff must be familiar with the relevant accident prevention instructions and must have received proper training in these.

Personnel are obliged to read and understand this User's Manual.

Personnel shall wear PPE (safety helmet, full body harness, shock absorber, lanyard, gloves, safety shoes and a slider compatible with the safety line of the ladder) at all times.

A copy of the User's Manual must be handed out to the personnel and must always be available for reference.

If more than one person is entrusted with one of the above tasks, the employer shall appoint a supervisor in charge of the operation.

Self-locking nuts must be used at all times. The screw must extend from the nut by at least half of the thread diameter. The nut may not be used once it has become possible to loosen by hand! If any damage or faults are found during operation, or if circumstances arise which may jeopardize safety: immediately interrupt the work in progress and notify the supervisor or employer!

All tests/repairs of electrical installations may only be performed by AVANTI or qualified personnel authorised by AVANTI.

All repairs to the traction, braking and supporting systems may only be performed by AVANTI or qualified personnel authorised by AVANTI.

If any supporting parts are repaired or replaced, the operational safety of the system must be tested and verified by AVANTI or qualified personnel authorised by AVANTI.

Only original fault-free parts may be used. Use of non-original parts will render the AVANTI's warranty void and any type approval invalid.

No modification, extension or reconstruction of the service lift is allowed without the AVANTI's prior written consent.

No warranty is provided against damage resulting from reconstruction or modification of equipment or use of non-original parts which are not approved by AVANTI.

Before using the lift perform an inspection by AVANTI or qualified personnel authorised by AVANTI.

The lift must be inspected at least once a year by an expert that has been trained by AVANTI. The service lift is designed for a lifetime of 20 years with a frequency of use of approximately 12.5 h/year of 250 h during lift. In case frequency of use is higher, service and inspections are required and replacement of components might be necessary according to the replacement criteria stated on the maintenance manual.

Service lift may not be used by persons who are under the influence of alcohol or drugs which may jeopardize working safety.

Service lift shall ONLY be used when the turbine is not generating power.

All wind farm site specific rules must be followed.

Service lift shall not be used during inclement weather, including wind speeds over 18 m/s.

Personnel shall be equipped with a wired or wireless two way communication device, that shall be connected to a location staffed by authorised personnel <sup>1)</sup>. Personnel shall be equipped with portable lights of minimum 200 lx <sup>1)</sup> (i.e. head-lamps).



*Avoid injury – follow all instructions!*



*The tower owner must verify the need for third party service lift inspections with the local authority and comply with the standards specified.*



<sup>1)</sup> Optional

## 2.4 Terms and definitions

Terms	Definitions
<b>Certified technician</b>	Person who has gone through the relevant training associated with the scheduled task from Avanti or from a certified trainer and is in possession of a valid (non expired) certificate for the task.
<b>User</b>	Person who has gone through the relevant training associated with the Avanti service lift use and daily inspection and is in possession of a valid (non expired) certificate for the task.
<b>Manual descent</b>	Action performed to descend the lift at a controlled speed without power supply by manually opening the hoist electromagnetic brake. (Also manual no-power descent)

## 3. Description

### 3.1 Purpose

The service lift purpose is to transport persons plus their tools and equipment to the most convenient height for performing work in wind turbine generators (WTG).

Its use is limited to personnel authorised by AVANTI holding the relevant training certificates. The access to the WTG and consequently to the service lift is controlled and forbidden to public access.

The service lift is used primarily to transport technicians, their tools and spare parts from the bottom platform (or lowest accessible point) to the top platform (or highest accessible point). It is also used to access intermediate platforms where inspection and service of WTG connecting bolts and other equipment is made.

### 3.2 Scope



*This manual contains the instructions for the Pegasus L03 bucket type version service lift.*

The Product comprises a service lift consisting of:

- a rack and pinion service lift,
- a ladder (mast),
- the necessary accessories to allow the connection to the WTG and the control and safety functions described in the manual. The accessories include: ladder supports (ties to the tower brackets), rest platforms, mechanical stops, safe zone plates, platform control boxes and other electrical equipment. It also includes the hardware necessary to make the connections, stickers and warning signs.
- and the platform fences.

The ladder sections, their supports, related accessories and platform fences may be assembled to the tower in the WTG factory and supplied later on site for final installation.

The service lift is supplied pre-assembled and may be supplied to the WTG factory or on site directly. Final assembly, adjustment, installation and verification of the service lift shall be made on site.

### 3.3 Exclusions

The WTG manufacturer will be responsible for ensuring full compliance of the system once integrated in the tower. To do so, the instructions and WTG requirements stated in this manual shall be observed.

For example, the emergency lighting along the WTG shall be considered, in order to guarantee a safe evacuation from WTG in case of emergency.



*The WTG manufacturer's risk assessment shall include a service lift integration study.*



*The service lift must not be used outdoor or in potentially explosive atmospheres.*



### 3.4 Technical specifications

Service lift		Pegasus L03
Door type		Bucket type, front fence (1.1 m) with double door
Service lift speed		19.4 m/min $\pm$ 10 % (50 Hz) 17.4 m/min $\pm$ 10 % (60 Hz)
Working load limit / N° persons (max)		250 Kg / 2 Persons
Maximum Travelling height		150 m
Operating temperature <sup>1)</sup>	Standard	-10°C to +60°C
	Low	-25°C to +40°C
Survival temperature <sup>1)</sup>	Standard	-25°C to +80°C
	Low	-40°C to +80°C
Traction system type		Rack and pinion
Max.noise level		80 dB (A)
Power supply		16 A 3 Phase 400V, 50Hz / 60Hz
IP protection / NEMA type <sup>1)</sup>		min. IP 54
Control voltage		24 VAC

<sup>1)</sup>Note: for special working conditions, check with the manufacturer

Traction system	Pegasus L03
Power	2 x 1.5 kW
Gear box ratio	1 : 15 (50 Hz)- 1 : 20 (60 Hz)
Rack / Pinion module	6
Centrifugal brake limiting speed	24 m/min (50 Hz) – 21 m/min (60 Hz)
Dimensions	220 x 225 x 580 mm
Weight by motor group	30 Kg
Motor speed	1400 rpm (50 Hz) – 1680 rpm (60 Hz)
Nominal current	2 x 3.7 A
Start current	2 x 18.5 A

Cabin	Pegasus L03
Cabin weight	225 kg
Outer dimensions (W x D x H)	996 x 777 x 2642 mm
Inner dimensions (W x D x H)	976 x 481 x 2232 mm
Door opening of bucket type (W x H)	920 x 1100 mm
Door opening of full sliding door (W x H)	564 x 1988 mm
Top hatch dimensions (W x D)	640 x 400 mm
Bottom hatch dimensions (W x D)	600 x 400 mm

Power & Control cable		Pegasus L03
Type	Bottom platform to junction box	18 G 2.5
	Top platform to junction box	8 G 1.5
	Travelling cable	1 x 8 G 2.5 + 1 x 10 G 1.5
Travelling cable weight (approx.)		0.6 kg/m

Ladder rack (Mast)	Pegasus L03
Standard dimensions (W x D x H)	530 x 30 x 1489 mm / 530 x 30 x 2978 mm
Weight (per piece)	15 kg / 30 kg
Attachment distance between ladder rungs	1 per mast section, max. 3000 mm

### 3.5 General arrangement of service lift inside a generic WTG

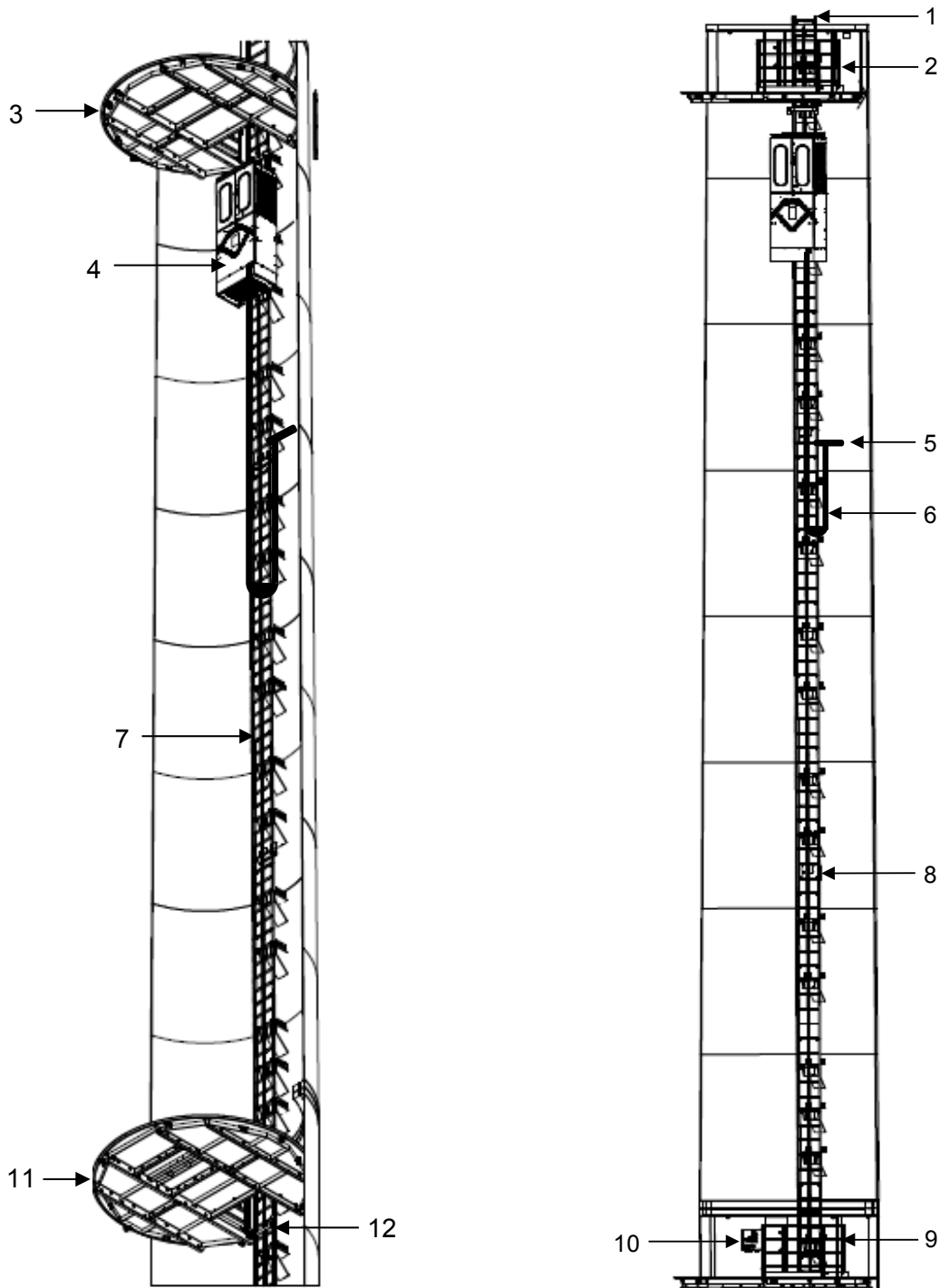

**i** The service lift features a travelling cable system. This system consists of a cable that is connected from the service lift to a support installed above the middle of the tower height. This way, the cable travels with the service lift.

1. Top mechanical stop
2. Top platform fence
3. Top platform
4. Service lift
5. Intermediate support
6. Travelling cable
7. Ladder rack
8. Rest platform
9. Bottom platform fence
10. Bottom platform control box
11. Bottom platform
12. Bottom mechanical stop

### 3.6 Service lift overview

#### 3.6.1 Bucket type

##### 3.6.1.1 Pegasus L03 bucket type

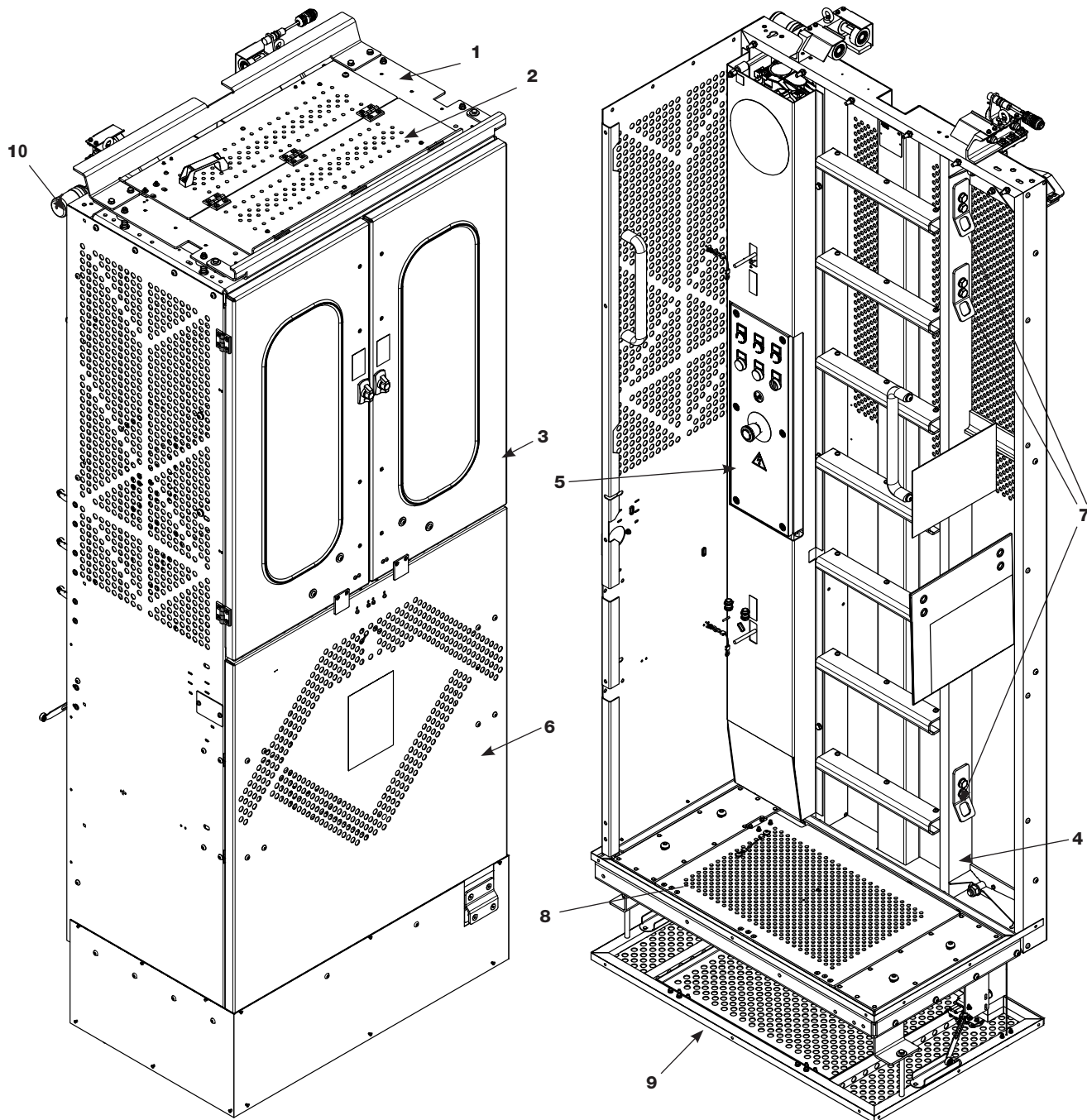

- 1. Top obstruction device
- 2. Top hatch
- 3. Double door
- 4. Main frame
- 5. Cabin control box

- 6. Fixed front
- 7. Anchor points for PPE (3x)
- 8. Bottom cabin hatch
- 9. Bottom obstruction device
- 10. Warning lights (2x) <sup>1)</sup>



<sup>1)</sup> Optional



### 3.7 Service lift dimensions

#### 3.7.1 Bucket type

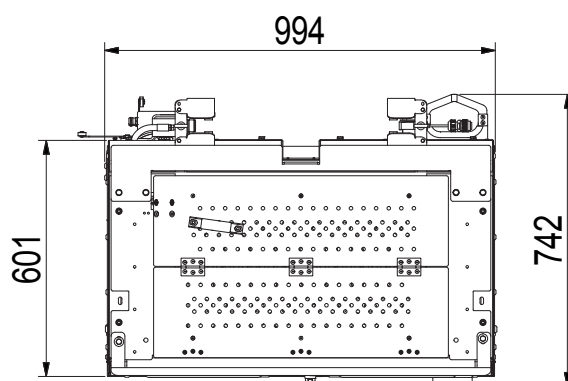
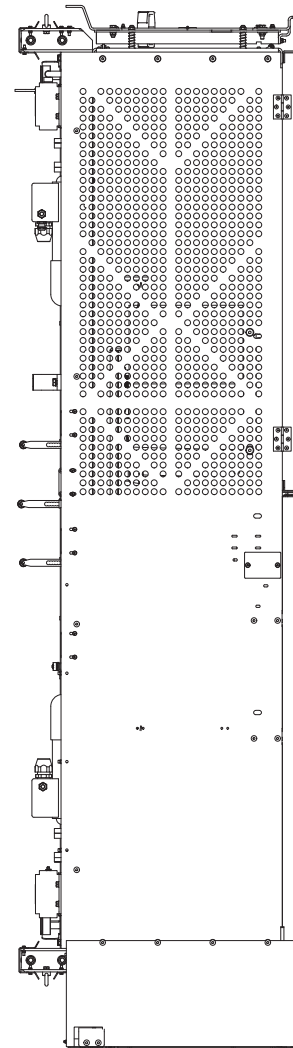
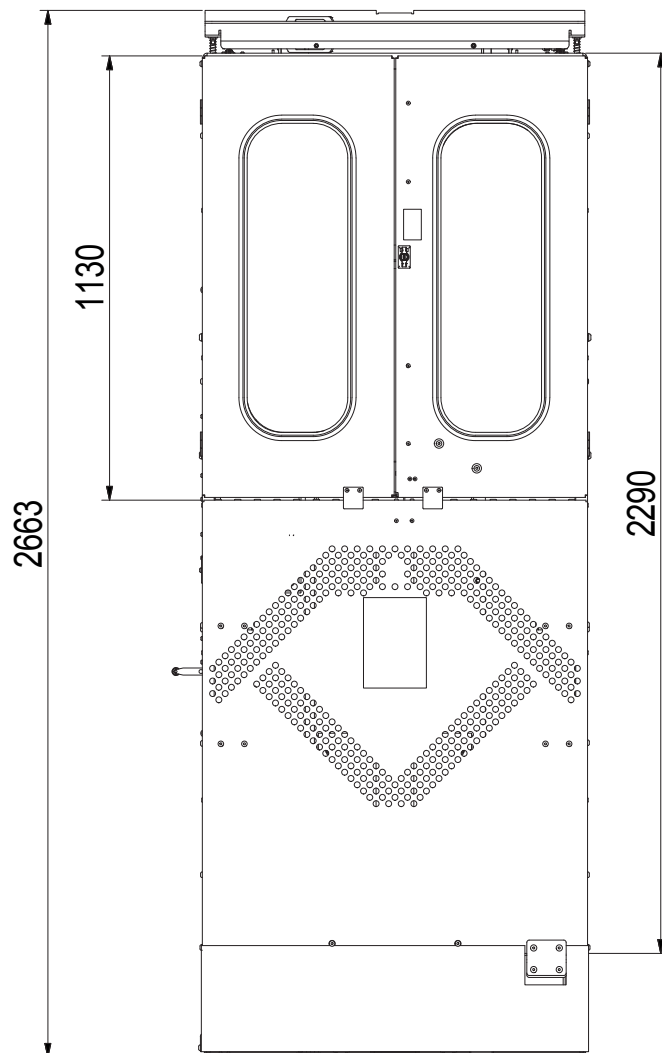

### 3.8 Main frame

The main frame is a welded steel structure. The traction and guiding systems are bolted to the main frame.

#### Pegasus L03:

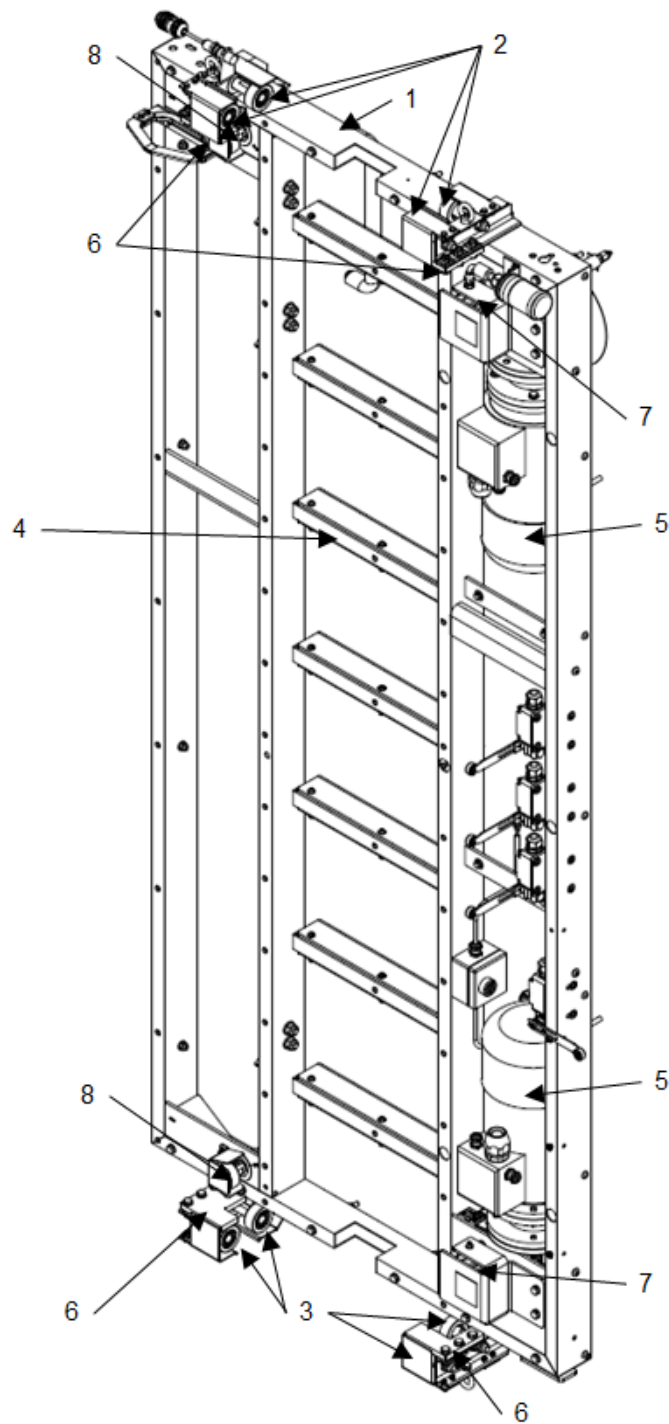

1. Main frame
2. Guiding rollers top
3. Guiding rollers bottom
4. Evacuation ladder
5. 2 Motor groups
6. Anti-derailment brackets
7. Pinions
8. Counter guiding rollers

## 3.9 Controls

### 3.9.1 Bottom platform control box

**i** The send and call buttons of the platform control boxes have a delayed response function. A buzzer is included on the cabin control box. This way, persons next to or inside the cabin are warned of imminent movement of the service lift and can react accordingly.

#### Send and call configuration:

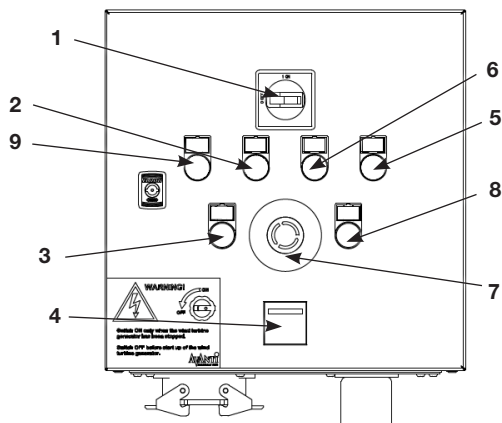

#### 1. ON/OFF MAIN SWITCH

**2. UP LIGHT (GREEN)**  
It lights up when the lift ascends.

**3. DOWN BUTTON (BLACK)**  
Press and hold DOWN button to call the lift downwards.

#### 4. HOUR COUNTER

**5. FAULT LIGHT (RED)**  
Lights up when there is an activated switch on the safety circuit i.e: Open door, emergency stop pressed, open hatch or the ON/OFF buttons of the cabin control box is not in the ON position.

#### 6. OK LIGHT (GREEN)

Lights up when the box has electric current.

**7. EMERGENCY STOP BUTTON (RED)**  
Press to interrupt any control function. Turn/pull to reset the control after necessary verifications.

**8. UP BUTTON (WHITE) (OPTIONAL)**  
Press and hold UP button to send the lift upwards.

#### 9. DOWN LIGHT (GREEN)

It lights up when the lift descends.

### 3.9.2 Cabin control box

#### For Pegasus L03:

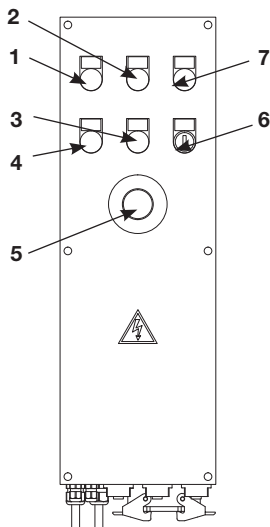

#### 1. FAULT LIGHT (RED)

It lights up when there is an activated switch of the safety circuit (i.e. a door or hatch is open, an emergency stop button is pressed, the ON/OFF selector is at the OFF position, or a limit switch is activated).

#### 2. PLATFORM LIGHT (GREEN)

It lights up when the lift reaches the bottom or top platform. If the platform switch (S18) is provided: the light lights up when the lift reaches any platform.

#### 3. DOWN BUTTON (BLACK OR WHITE)

Press and hold it to descend.

#### 4. UP BUTTON (BLACK OR WHITE)

Press and hold it to ascend.

#### 5. EMERGENCY STOP BUTTON (RED)

Press to interrupt any control function. Turn/pull to reset the control after necessary verifications.

#### 6. ON/OFF SELECTOR (GREEN)

It lights up when all the switches of the safety circuit are deactivated and the ON/OFF selector is at the ON position. Select the ON position to enable control from the lift. Select the OFF position to interrupt control from the lift.

#### 7. OVERLOAD LIGHT (YELLOW)

It lights up when the cabin is overloaded.

**i** Cabin control box inside the cabin has control priority over control boxes at platforms.

### 3.9.3 Mid tower junction box

Pegasus L03 Send and call configuration:

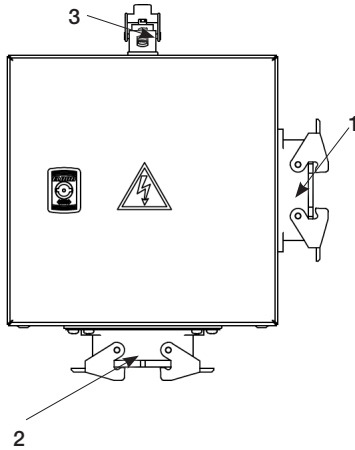

1. Connector for travelling flat cable  
To supply electric power to the cabin.
2. Connector for electrical round cable  
To connect to bottom platform control box.
3. 12 pin connector for electrical round cable  
To connect to top platform control box.

### 3.9.4 Top platform control box

Send and call configuration:

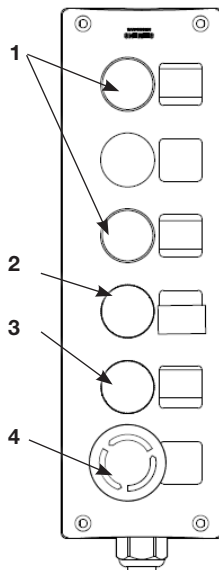

1. **UP/DOWN LIGHT BUTTONS (GREEN)**  
Press and hold UP/DOWN light-buttons to ascend or descend the service lift respectively. UP/DOWN light-buttons light up when the lift is ascending or descending respectively.
2. **READY LIGHT (GREEN)**  
It lights up when the box has electric current.
3. **FAULT LIGHT (RED)**  
It lights up when there is an activated switch on the safety circuit (i.e. an open door, emergency stop button pressed, open hatch or the ON/OFF selector of the cabin control box is not in the ON position).
4. **EMERGENCY STOP BUTTON (RED)**  
Press to interrupt any control function. Turn/pull to reset the control after necessary verifications.

### 3.10 Service lift doors

#### 3.10.1 Pegasus L03 double door

The double door consist of two hinged door leaves that open outwards. Every one has its own mechanical lock and opening monitoring switch. If any of the two doors is opened, the lift stops. This system is allowed with perforated doors and transparent windows.

Mechanical locks block every door to the fixed front and to the fixed roof. It present two door knobs outside the cabin and two inside.

To open the right door from the outside of the cabin, turn the knob 120° clockwise, pull to open and then, release knob. To open the left door from the outside of the cabin, turn the knob 120° counter clockwise , pull to open and then, release knob.

To close the right door from the outside of the cabin, turn the knob 120° clockwise , push towards inside and, when the door is totally closed, release knob and turn it counter clockwise to lock the door. To close the left door from the outside of the cabin, turn the knob 120° counter clockwise , push towards inside and, when the door is totally closed, release knob and turn it clockwise to lock the door.

To open the right door from the inside of the cabin, turn the knob 120° clockwise , push to open and then, release knob. To open the left door from the inside of the cabin, turn the knob 120° counter clockwise , push to open and then, release knob.

To close the right door from the inside of the cabin, turn the knob 120° clockwise, pull from the handle towards inside and, when the door is totally closed, release knob and turn it counter clockwise to lock the door.

To close the left door from the inside of the cabin, turn the knob 120° counter clockwise , pull from the handle towards inside and, when the door is totally closed, release knob and turn it clockwise to lock the door.

From outside:

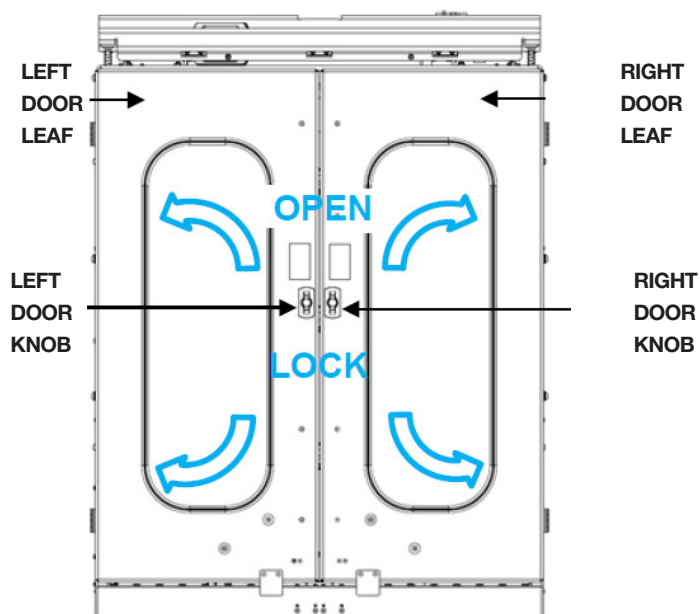

From inside:

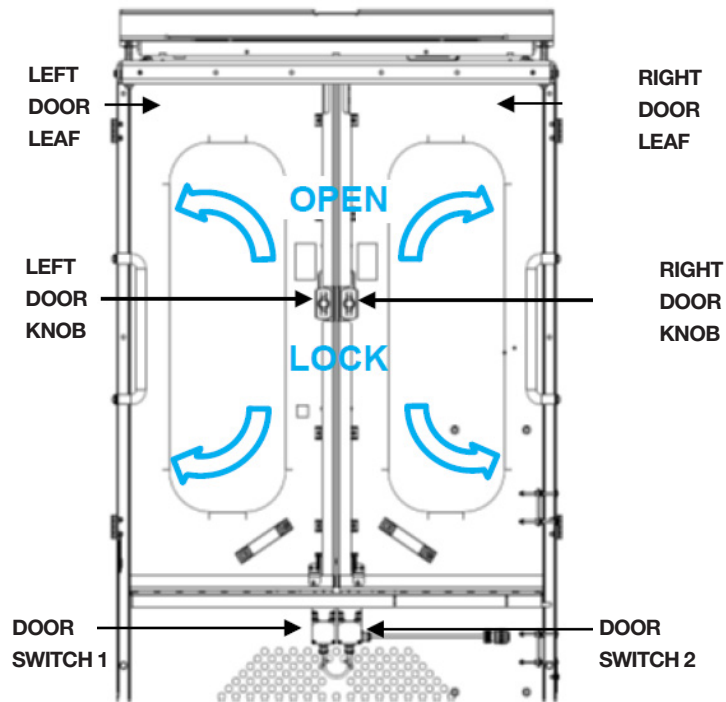

If the door is not closed properly, the fault light (red) will light up.



The steps inside the cabin are provided with non-slip surface to mitigate the risk of falling.



When the door is open, user(s) **MUST BE** attached with the shock absorber to a cabin anchor point.





### 3.11 Front windows

The service lift features perforations that allow ventilation and visibility inside the cabin. Additionally, the service lift may feature front windows to improve visibility.

Bucket type without windows:

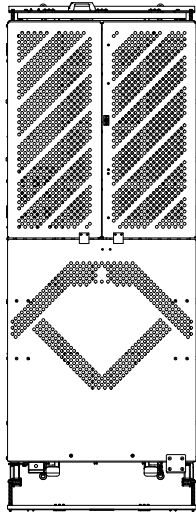

Bucket type with windows:

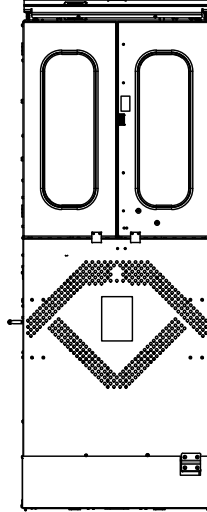

### 3.12 Top hatch

The top hatch consists of a double hinged sheet, that minimizes necessary space to open it. This hatch is used to evacuate the service lift or to access the top platform.

Pegasus L03:

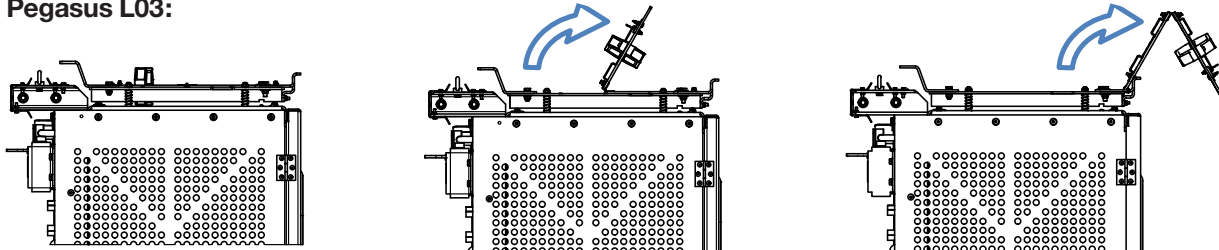

The dimensions of the clear opening are 640 x 400 mm. A switch interrupts control if the hatch is open or not properly closed. In this case the fault light illuminates. The top hatch is mounted over a top floating frame. If a person stands on the top floating frame, a switch is triggered and control is interrupted. This prevents misuse of the service lift; e.g. persons riding on top. A rubber bumper is mounted to protect switch from crushes and misuse, forcing user to close the hatch properly.

1. Top hatch switch actuator
2. Top hatch switch

Pegasus L03:

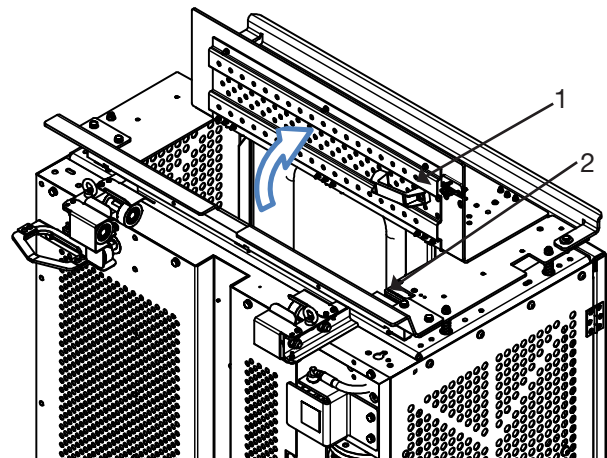



### 3.13 Bottom hatches

The bottom cabin hatch and the bottom obstruction hatch consist of a perforated sheet that open inwards and outwards respectively. They are used in case of evacuation. A corresponding switch interrupts control if one these hatches is opened or not closed properly. In this case the fault light of the cabin control box illuminates. The dimensions of the clear opening are 600 x 400 mm.

1. Bottom cabin hatch switch actuator
2. Bottom cabin hatch switch
3. Bottom obstruction hatch switch
4. Bottom obstruction hatch switch actuator

#### Pegasus L03:

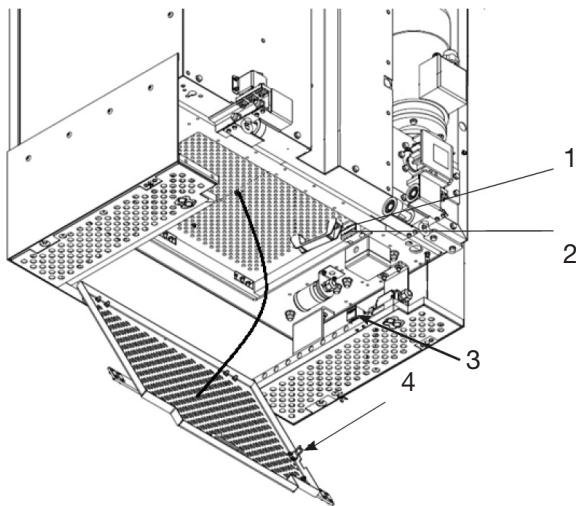

### 3.14 Top obstruction device

The top obstruction device interrupts control if it encounters an obstacle.

1. Top obstruction switches (4x)
2. Top floating frame
3. Top fixed frame
4. Top hatch switch
5. Top hatch
6. Top limit plate
7. Top limit switch

#### Pegasus L03:

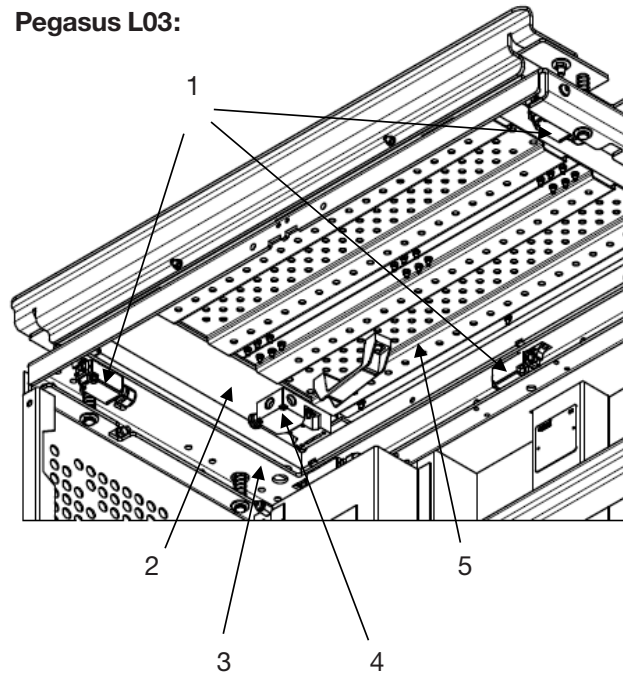



### 3.15 Top limit switch

The top limit switch interrupts ascent if the service lift reaches top platform.

**Pegasus L03:**

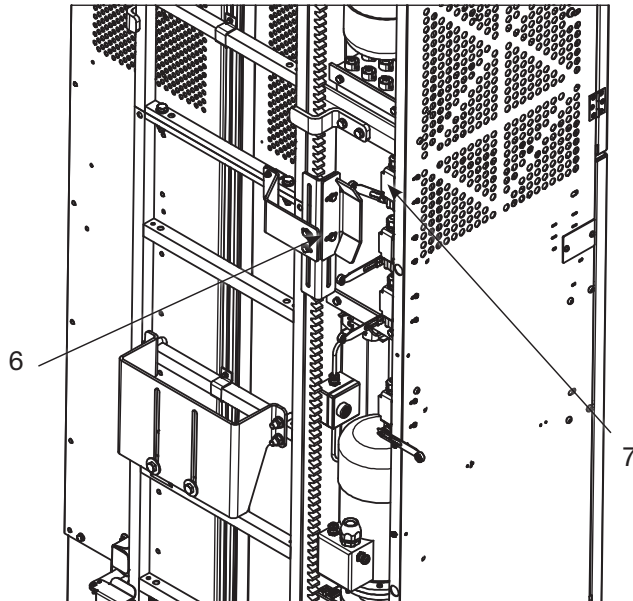

### 3.17 Emergency limit switch

The emergency limit switch interrupts the control if the top limit switch or top obstruction switches fail, or if bottom limit switch or bottom obstruction switches fail. The emergency limit switch is triggered by the bottom limit plate and top limit plate located at the bottom and top platforms respectively. To release the switch at the bottom platform: temporarily remove the switch lever, put the lever back afterwards and verify adjustment. To release the switch at the top platform, perform manual descent some metres.

1. Emergency limit switch (S13)
2. Top or bottom limit plate

**Pegasus L03:**

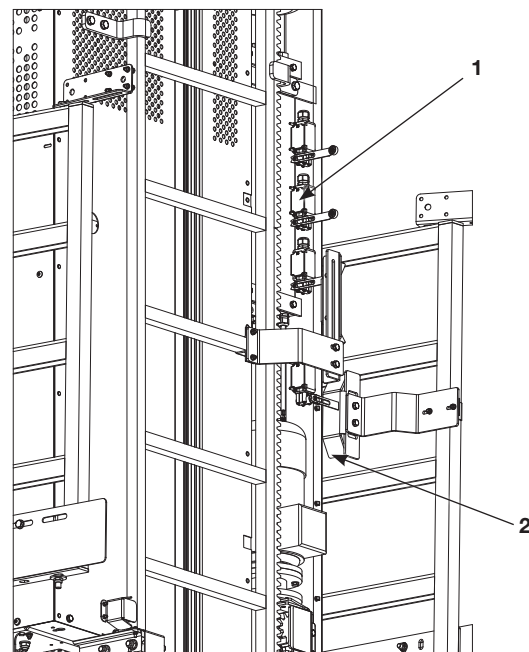

### 3.16 Bottom obstruction device

#### 3.16.1 With bottom limit switch configuration

The bottom obstruction device interrupts descent if it encounters an obstacle. The bottom limit switch interrupts descent if the service lift reaches the bottom platform.

1. Bottom limit plate
2. Bottom limit switch
3. Bottom mechanical stop
4. Bottom obstruction switches

**Pegasus L03:**

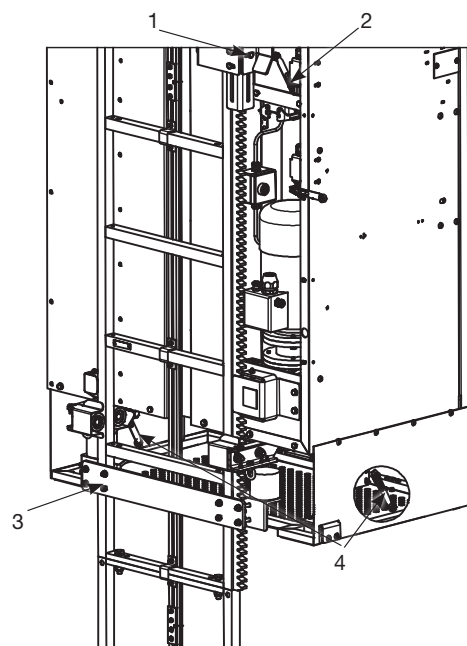



### 3.18 Top and bottom mechanical stops

The top and bottom mechanical stops are installed on the ladder and act as travel limits in case that the top or bottom limit switches, and the emergency limit switch fail to trigger.

1. Top mechanical stop
2. Top obstruction device
3. Top arms
4. Bottom mechanical stop
5. Bottom arms

**Pegasus L03:**

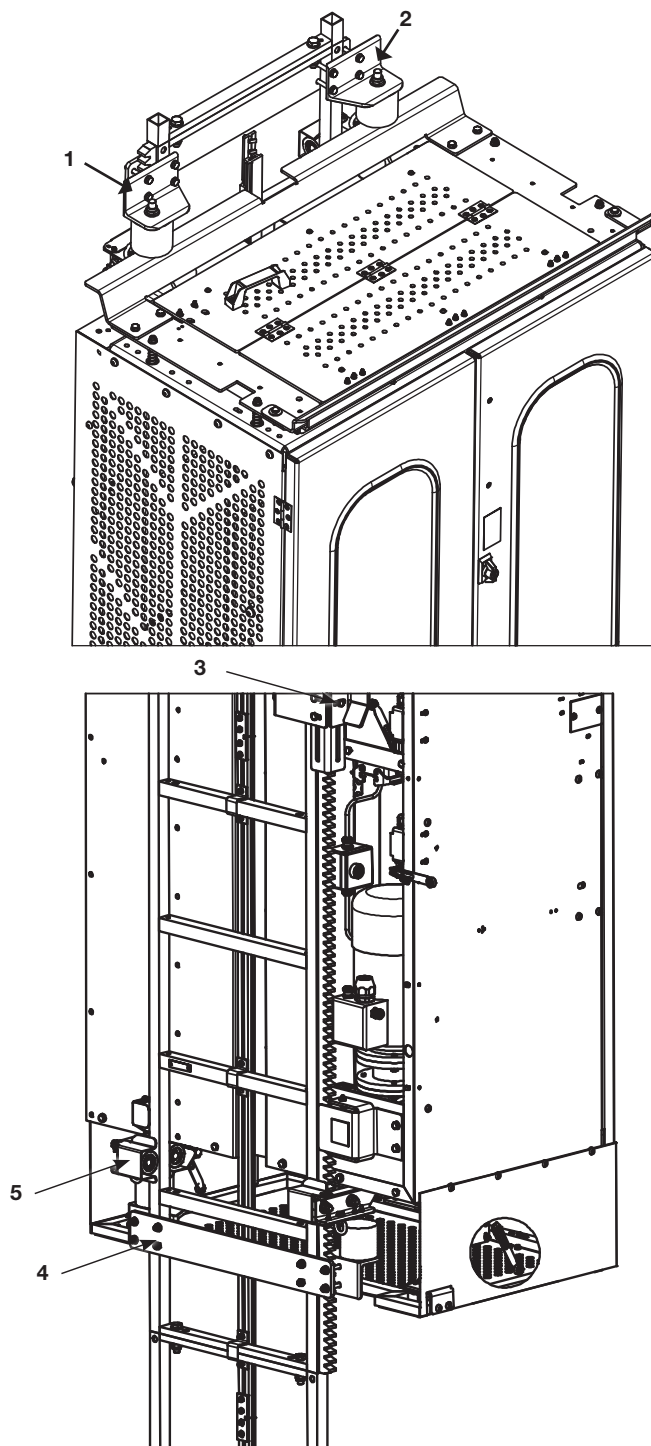



### 3.19 Traction system

The traction system is rack and pinion type. The system has two motor group working on the same rack. They are installed on the main frame of the cabin. Each motor groups has a centrifugal brake, a gear box, a pinion and a brake motor. Each motor brake includes a manual release lever allowing a manual descent in absence of electric current.

1. Pinion
2. Gear Box
3. Centrifugal brake
4. Motor
5. Manual descent actuator
6. Inductive sensor
7. Guiding rollers
8. Anti-derailment brackets

**Pegasus L03:**

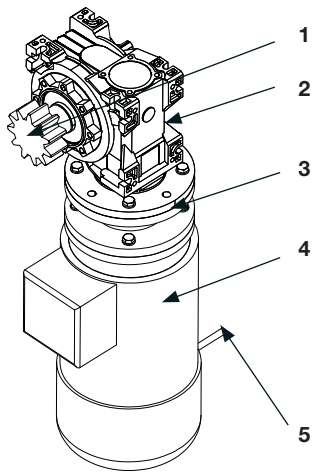

### 3.20 Guiding and anti-derailment system

The service lift is guided along the stiles of a ladder by means of ten guiding rollers.

An inductive sensor detects the presence of the stile. If the stile is not detected (bigger distance than setting), control is interrupted, avoiding derailment of the service lift.



*After a short circuit, check that the inductive sensor and its light work properly.*

The service lift features anti-derailment brackets (4 for Pegasus L03), that prevent derailment if guiding rollers fail.

**Pegasus L03:**

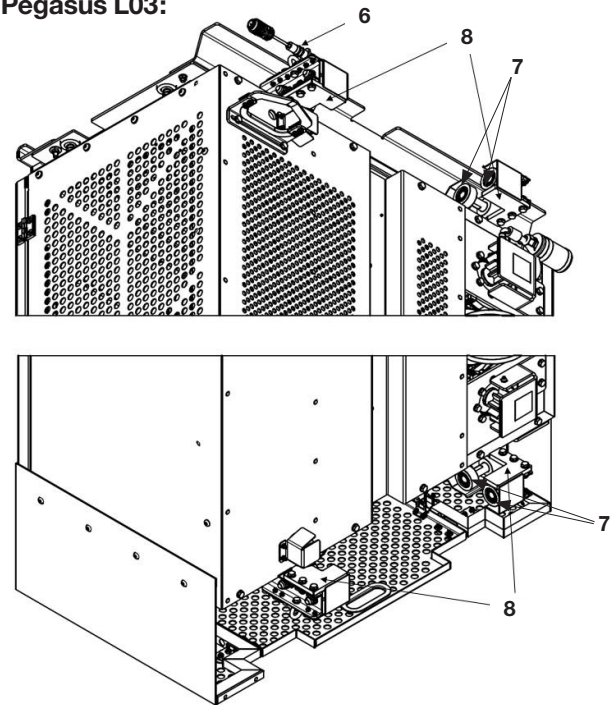

### 3.21 Overload limiter

The overload limiter prevents any movement of the service lift in the event of an overload. In case of an overload, the overload light (yellow) lights up. The overload limiter consists of a floating floor with four load cells. The load cells send the load signal to the electronic equipment of the cabin control box.

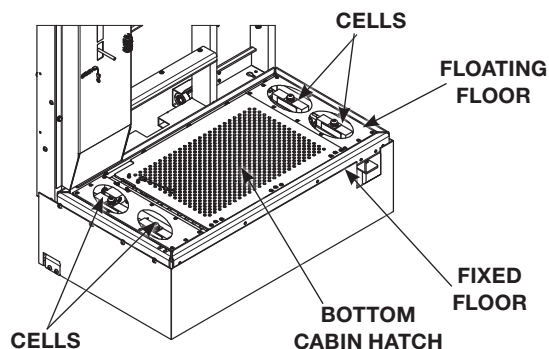

### 3.22 Manual descent system

Each motor group features a hand lever, that allow manual release of the motor electromagnetic brake. Once the motor brakes are released, the service lift descends with a controlled speed limited by the centrifugal brake installed in each motor group.



*Push hand levers upwards and downwards at the same time to perform manual descent and always look through the perforated sheet holes.*

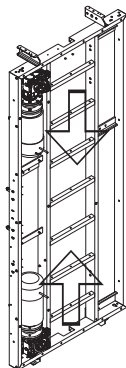

### 3.23 Rest platforms

Rest platforms are self folding using torsion springs so they do not interfere with the cabin movement when they are not used.

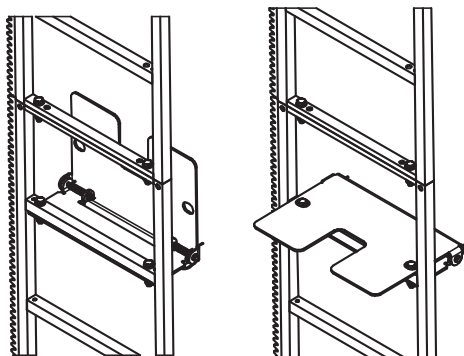

### 3.24 Anchor points for PPE

The service lift is equipped with yellow anchor points inside the cabin.

Version	Number of users	Number of anchor points
Pegasus L03 bucket type	2	3



*Each anchor point may only be used by one user simultaneously.*

1. Top cabin anchor point
2. Bottom cabin anchor point

Pegasus L03:

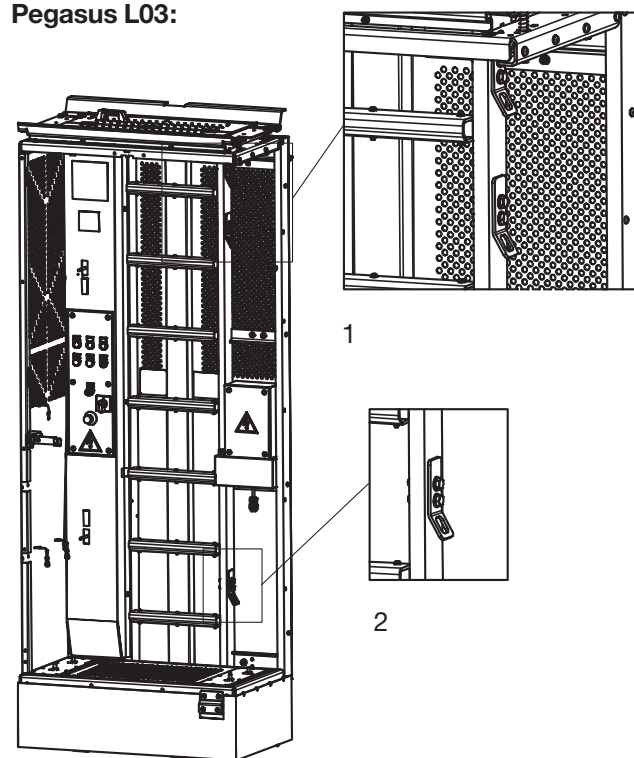

### 3.25 Information signs and documents

The following documents, signs and stickers are supplied with the service lift and shall always be available.

Document	Position
Serial number plate	Inside the cabin.
Manual	Inside the blue bag.
Quick guide	Inside the cabin.
Evacuation guide	Inside the cabin.
Rescue guide	Close to the bottom platform
Use of PPE sticker	On the motor cover.
Work load / N° persons sticker	On the front side of the cabin
Warning risk of falling sticker	Inside the cabin
Warning risk of crushing sticker (2x)	On the pinion covers.
Manual descent sticker (2x)	On the motor cover.
Wiring diagram	Inside the bottom platform control box.
Electrical warning disconnection sticker	On the bottom platform control box.
Alignment stickers	Inside the cabin 4) and at each landing
Lubrication sticker	On the motor cover.
No standing on top sticker <sup>1)</sup>	On the cabin
Maintenance brake sticker	Inside the cabin.
Electrical hazard sticker	On the cabin control box.
Platform alignment stickers	Outside the cabin.
Fall and trap risks	Close to the platform fences.

 <sup>1)</sup> Optional

### 3.26 Cabin light <sup>1)</sup>

The service lift is equipped with a light inside the cabin. When service lift is connected to power supply, this light illuminates at all times.

The cabin light is battery packed in order to illuminate the inside of the cabin in case of a power failure. When fully charged, it will last at least for 30 minutes.

### 3.27 Warning lights <sup>1)</sup>

A set of warning lights is mounted on the top and on the bottom of the service lift. The flashes warn that the service lift is moving.

### 3.28 Platform fences

The platform fences protect users from falling through the service lift hole at platforms.



*These platform fences shall comply with:*

- EN 14122-3 for Pegasus bucket type version. They shall have non-slip rails or steps facilitating access to the lift and to the guiding ladder from the platforms and shall have no doors.

## 4. Instructions for use

### 4.1 Daily inspection

-  *Daily inspection of the service lift shall only be carried out by personnel authorised by AVANTI. If there is more than one user, the employer shall appoint a supervisor in charge of the daily inspection.*



*The daily inspection shall be carried out following the instructions provided in "Appendix A: Daily inspection". The instructions provided on this page shall be used only as guidelines.*

#### 4.1.1 Travel zone

1. Ensure that there are no obstacles within the service lift's travel zone which may obstruct the travel of the cabin or hit the cabin.
2. Ensure that the ladder rack is solidly and safely fixed.

#### 4.1.2 Visual inspection

1. Check that the service lift components are mounted in accordance with the specifications and without any noticeable defects or missing components.
2. Check that the traction system (ladder rack & pinion) is not damaged or jammed.
3. Check that the guided system is not damaged or jammed.
4. Check that the two motor groups are in good conditions and not damaged.

#### 4.1.3 Functional inspection

Check that the safeties are in place and working.

##### 4.1.3.1 Bottom platform control box

1. Main switch ON/OFF: Turn the ON/OFF electric isolator on the bottom platform control box to the OFF position. The green light shall be OFF. The service lift shall not run. Turn it ON; the green light shall be ON.
2. Emergency stop button: The service lift shall not move UP/DOWN. Release the emergency stop button and drive the lift UP approximately 1 m.
3. Press UP/DOWN buttons on the control box. The lift should travel upwards or downwards.

##### 4.1.3.2 Cabin control box

1. ON/OFF selector: Turn the ON/OFF selector on the cabin control box to the OFF position. The green light shall be OFF. The service lift shall not be able to run. Turn it ON; the ready light (green) shall be ON. The service lift shall be able to run.
2. Emergency stop button: Press the emergency stop button. The service lift shall not move UP/DOWN. Release the emergency stop button and drive the lift UP approximately 1m.
3. Fault light: Press the emergency stop button, the fault light (red) of the cabin control box shall be ON.
4. Top and bottom hatch: Open the hatch, the fault light (red) shall be ON and the lift shall not move UP/DOWN.
5. Service lift door: Open the door, the fault light (red) shall be ON and the lift shall not move UP/DOWN.
6. Drive the service lift DOWN until the bottom obstruction device hits the bottom mechanical stop. The lift shall stop.
7. Drive the service lift UP until the top obstruction device hits with the top mechanical stop. The lift shall stop.
8. Pull down the top hatch handle until the roof switch is activated, the fault light (red) shall be ON and the lift shall not move.

##### 4.1.3.3 Manual descent

1. Ascend the service lift 1 m.
2. Check that manual descent can be performed to the bottom platform.

##### 4.1.3.4 Electromagnetic brakes

1. While performing manual descent, release one of the manual descent actuators.
2. Check that the service lift stops.
3. Repeat the steps 1 & 2 with the other manual descent actuator.



## 4.2 Cautions

Aspects to consider for a good use of the service lift:

1. No person shall be on the ladder when the service lift is in operation.
2. The service lift shall be free of objects.
3. No objects shall be located on the top of the cabin.
4. Electrical system shall be properly insulated.



*The ladder and rest platforms must be used only for evacuation or when the service lift is out of service.*



*When attaching the shock absorber to the guiding ladder, it must be hooked to the right stile (no rack side).*



*In the bucket type version: users inside the cabin shall be attached to an anchor point when door is open. In full sliding door versions, users inside the cabin shall be attached to an anchor point at all times.*

## 4.3 Prohibited uses



*The following prohibitions shall be observed when using the service lift. The consequences of not following them are extremely hazardous to the physical integrity of the users.*

1. Do not use the service lift beyond its intended purpose.
2. Do not operate the lift without following the safety warnings and operating instructions.
3. Do not load the service lift more than its rated load.
4. Do not try to repair machine components.



*Only personnel from AVANTI or qualified personnel authorised by AVANTI are allowed to carry out service on the service lift.*

5. Do not travel on service lift roof.
6. Do not use the emergency manual release of the guard locking of door lift or fence doors during normal use.
7. Do not manipulate switches or safeties.
8. Do not disattach trapped key from wire rope.
9. Do not have a second trapped key.

## 4.4 Operation from inside the cabin

1. Turn the ON/OFF main switch of the bottom platform control box to the ON position.
2. Open the door, climb the fence-railing, go inside and close the door.
3. Turn the ON/OFF selector of the cabin control box to the ON position.
4. To go up or down, press and hold the UP or DOWN button as needed.

## 4.5 Operation from bottom platform

To send or call the service lift from the bottom platform control box:

1. Check that the ready light is illuminated.
2. Check that the fault light is not illuminated.
3. Press and hold the UP or DOWN button.



*Coordinate send or call actions between personnel by means of walkie-talkies.*



*The transportation of persons is forbidden if the operation is controlled from the platforms.*

## 4.6 Operation from top platform

To send or call the service lift from the top platform control box:

1. Check that the ready light is illuminated.
2. Check that the fault light is not illuminated.
3. Press and hold the UP or DOWN button.

## 4.7 Landing alignment

The service lift can be landed at any platform totally aligned to permit safe egress and ingress. To do so:

1. Travel to desired platform (bottom, intermediates and top one).
2. Locate the service lift so that alignment sticker of inside the cabin overlaps alignment sticker of the ladder.
- 2B. If a platform switch is provided, locate service lift so that platform light of cabin control box illuminates.
3. Exit from cabin can be done safely.



*Before closing the lift door, ensure that your equipment (i.e.lanyards) do not get trapped/tangled with the closing door and/or with surrounding elements.*



*To prevent the lanyards from tangling with surrounding elements, keep them properly attached to your body harness.*



*To prevent the lanyards from tangling with the moving service lift, do not get close to the hoistway.*



## 4.8 Entering and exiting the cabin

### 4.8.1 Pegasus L03 bucket type

To enter the cabin:

1. Turn the right external door knob 120° clockwise.
2. Pull from the turned knob to open the right leaf.
3. Turn the left external door knob 120° counter clockwise.
4. Pull from the turned knob to open the left leaf.
5. Attach the shock absorber to the cabin point.
6. Climb up the platform fence.
7. Hold the cabin handles and climb down the cabin steps.
8. Turn the right door's knob 120° clockwise, pull from the door's handle towards inside and, when the door is totally closed, release knob and turn it counter clockwise to lock the right door.
9. Turn the left door's knob 120° counter clockwise, pull from the door's handle towards inside and, when the door is totally closed, release knob and turn it clockwise to lock the left door.

To exit the cabin:

1. Attach the shock absorber to the cabin anchor point.
2. Turn the right door's knob 120° clockwise, push the door while the knob is turned, when the door is opened, release the knob.
3. Turn the left door's knob 120° counter clockwise, push the door while the knob is turned, when the door is opened, release the knob.
4. Hold the cabin handles and climb up the cabin steps.
5. Climb down the platform fence.
6. Release the shock absorber to the cabin point.
7. Turn the right door's knob 120° clockwise, push towards inside and, when the door is totally closed, release knob and turn it counter clockwise to lock the door.
8. Turn the left door's knob 120° counter clockwise, push towards inside and, when the door is totally closed, release knob and turn it clockwise to lock the door.

### 4.8.2 Top / Bottom hatch

To enter the cabin:

1. Climb the ladder attached to the fall protection system or attach the shock absorber to the tower anchor.
2. Open the hatch.



*When opening the bottom obstruction hatch from outside the cabin, hold the hatch until it is completely open.*

3. Attach the shock absorber to the cabin anchor point.
4. Release the fall protection device or shock absorber from the tower anchor point to enter the cabin.
5. Climb inside the cabin holding the handles and the cabin main frame ladder as support.
6. Close the hatch

To exit the cabin:

1. Attach the shock absorber to the cabin anchor point.
2. Open the hatch.



*Prior to opening the bottom obstruction hatch from inside the cabin, look through the perforated hatches to check that nobody is under the hatches.*

3. Climb out of the cabin using the handles and the cabin main frame ladder as support.
4. Attach to the fall protection system or attach the shock absorber to a tower anchor point.
5. Release the shock absorber on the cabin anchor point.
6. Close the hatch.



*WTG manufacturer must ensure that access to the top platform or nacelle can be done safely to avoid risk of falling.*

## 4.9 Emergency stop button

Release the UP/DOWN buttons and the service lift should stop. If it does not, push the emergency stop button, and all controls should be disabled.

Turn / pull the emergency stop button to reset the control.

## 4.10 Manual descent

In case of power failure or an operation fault, a controlled descent without power can be performed. To do so:

1. Remove the seals of the hand levers of the motor brake.
2. Check that there are no obstacles or person on the way.
3. Push the top and bottom hand levers simultaneously, downwards and upwards respectively. The service lift will start descending.
4. To stop, simply loosen the hand lever.



A buzzer <sup>1)</sup> will sound during manual descent.



The manual descent shall only be performed if it is strictly necessary.



During manual descent, the door and hatches of the lift shall be kept closed. Do not extend body parts outside the cabin during travel.



Always look through the perforated floor of the cabin to see if anyone is standing on the ladder.



Use the walkie-talkie to report about the manual descent.



During the manual descent, stop the service lift just before reaching the bottom platform floor. This way, the bottom obstruction device will not get damaged.



The manual descents shall be of maximum 30 m. Between two consecutive manual descents, the user shall wait minimum 10 minutes for centrifugal brakes to cool down. This way, the premature wear of the centrifugal brakes will be prevented. In case of real emergency (risk of death or for the integrity and security of users) a manual descent without intermediate stops can be performed. Then the centrifugal brakes shall be inspected by AVANTI or qualified personnel authorised by AVANTI.



<sup>1)</sup> Optional.

## 4.11 Rest platforms

If use of rest platforms is needed:

1. Climb up on the ladder to be one step above the rest platform.
2. With the safety of all your PPE, push down the rest platform with your foot.
3. Once platform is properly supported on the rung, stand over it with both feet.
4. The rest platform returns to its folded position once it is not in use.

## 4.12 Service ladder

The service lift uses a ladder as support and guide. In case of failure of the lift, this ladder is used to evacuate people (see the “Evacuation Guide”).



Always wear all the PPE and attach the fall protection device to the fall protection rail system of the ladder. User(s) in a rest platform **MUST ALWAYS BE** attached safely to the fall protection system.

## 4.13 Troubleshooting

All tests and repairs to the electric components shall only be carried out by AVANTI or qualified personnel authorised by AVANTI.

Repairs to the motor group and to the system's supporting components shall only be carried out by AVANTI or qualified personnel authorised by AVANTI.



The wiring diagram is placed in the bottom platform control box.





If these steps do not identify the cause and rectify the fault: consult AVANTI or qualified personnel authorised by AVANTI.

Breakdown	Cause	Solution
<p>The service lift cannot ascend nor descend.</p>  <p><b>STOP</b></p> <p><b>DANGER!</b> Attempting to use the lift will jeopardize work safety.</p>	<p><b>A1 The fixed EMERGENCY STOP button is activated.</b></p>	Turn this button clockwise until it moves out to deactivate it.
	<p><b>A2 Rack or pinions are damaged.</b></p>	<p>a) Check the damage. b) Evacuate the cabin.</p>
	<p><b>A3 The service lift is stuck on an obstacle.</b></p>	<p>a) Remove the obstacle. b) Test the operational safety of affected tower sections. c) Inform the supervisor.</p>
	<p><b>A4 Power failure.</b> a) Main switch is set to OFF. b) Grid voltage is interrupted. c) Supply between grid connection and control is interrupted.</p>	<p>a) Turn the main switch to ON. b) Find the cause and wait for the power to return. c) Test and if necessary repair the supply cable, fuses, and/or wiring from the control box.</p>
	<p><b>A5 Two phases are changed in the supply.</b></p>	Have AVANTI or qualified personnel authorised by AVANTI switch the two phases in the plug.
	<p><b>A6 The hatches or door switches are triggered.</b></p>	Check that door and hatches are properly closed.
	<p><b>A7 Motor thermal protection.</b></p>	<p>a) Rearm. b) If repeated, contact AVANTI.</p>
	<p><b>A8 ELECTROMAGNETIC BRAKES do not open.</b></p>	<p>a) Check voltage to the electromagnetic brakes. b) Check the springs. c) Check the brake disc. d) Regulate the brake disc.</p>
	<p><b>A9 MAGNETIC THERMAL CONTROL.</b></p>	<p>a) Rearm. b) If repeated, contact AVANTI.</p>
	<p><b>A10 CONTROL DIFFERENTIAL.</b></p>	<p>a) Rearm. b) If repeated, contact AVANTI.</p>
	<p><b>A11 OVER VOLTAGE PROTECTION.</b></p>	<p>a) Rearm. b) If repeated, contact AVANTI.</p>
	<p><b>A12 EMERGENCY TOP AND BOTTOM LIMIT SWITCH is activated.</b></p>	<p>a) At top platform, perform manual descent until the switch is released. b) At bottom platform, disassemble the bottom plate safe zone until the switch is released. c) Check the position of the safe zone plates. d) Check the top and bottom mechanical stop position.</p>
	<p><b>A13 OVERLOAD (overload light illuminates).</b></p>	<p>a) Test and if possible reduce the load, until overload lights stops illuminating. b) If repeated, contact AVANTI.</p>
	<p><b>A14 (If trapped key system <sup>1)</sup> is provided) the trapped key is not present or the trapped key switch is in the OFF position.</b></p>	Insert the key and turn it to the ON position.
	<p><b>A15 (If guard locking system <sup>1)</sup> of fences is provided) the guard locking switch is defective.</b></p>	Test / repair defective components.



<sup>1)</sup> Optional feature. Not necessary for bucket type version.



Breakdown	Cause	Solution
	<b>A16 TOP OBSTRUCTION DEVICE is activated.</b>	a) Check the springs. b) Move the lift down until the top obstruction switches are released.
<p>The service lift can descend but cannot ascend.</p> 	<b>B1 The service lift is stuck under an obstacle.</b>	a) Carefully move the service lift downwards and remove the obstacle. b) Test the operational safety of the affected platform components. c) Inform the supervisor.
	<b>B2 INDUCTIVE SENSOR is activated.</b>	a) Check section ladders. b) Check the status LED.
	<b>B3 (If provided) Top limit switch is activated.</b> a) Top limit switch is defective or not connected. b) Top limit switch is activated.	a) Test the top limit switch connection / function. Replace if necessary. b) Descend the service lift until the top limit switch is released.
<p>The service lift can ascend but cannot descend.</p> 	<b>C1 (If provided) Bottom limit switch is:</b> a) defective. b) activated.	a) Test the bottom limit switch connection / function. Replace if necessary. b) Ascend service lift until bottom limit switch is released.
	<b>C2 Bottom obstruction switches are:</b> a) defective. b) activated.	a) Test the bottom obstruction switches connection / function. Replace if necessary. b) Ascend service lift until bottom obstruction switches are released.
	<b>C3 The service lift is stuck on an obstacle.</b>	a) Carefully move the service lift upwards and remove the obstacle. b) Test the operational safety of the affected platform components. c) Inform the supervisor.
 <p>The service lift can ascend and descend but motor hums loudly.</p>	<b>D1 Motor is damaged.</b>	Contact AVANTI.

## 4.14 Out of Service

### 1. Securing the service lift:

Bring the service lift all the way down, until the lift reaches bottom platform.

### 2. Turn off the main switch to prevent inadvertent operation of the lift:

Turn the main switch to the OFF position. Power supply is now interrupted. Mark the lift "OUT OF SERVICE" and padlock as necessary. Contact AVANTI or qualified personnel authorised by AVANTI.

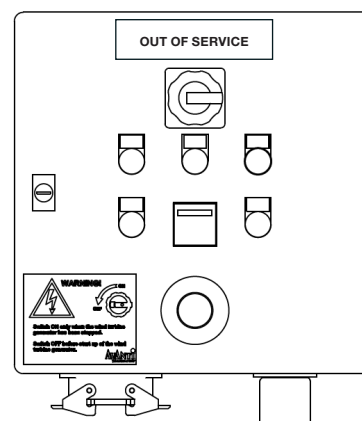

# Appendix B: AVANTI lift anchor point

## B.1 Caution

AVANTI LIFT ANCHOR POINT is an anchor point used for protection against falls from heights intended for use with a full body harness approved according to EN 361 or Z359.1:2007 as applicable. Connection to the LIFT ANCHOR POINT is only allowed by using self-closing connectors according to EN 362 or Z359.1:2007 as applicable.

Use in connection with other equipment than specified, may be potentially dangerous. User shall be equipped with a means of limiting the maximum dynamic forces exerted on the user during the arrest of a fall to a maximum of 6kN. In case of doubt, please contact AVANTI.

The maximum load that can be transmitted in service from the anchor device to the structure is 22.2 kN in  $\pm 15^\circ$  vertical direction. The maximum deflection of the anchor point that can occur in service is 10mm.

AVANTI LIFT ANCHOR POINT is tested and approved only to be mounted on AVANTI lifts. This manual always needs to be represented in language of sale and provided for use by all technicians. Activities at height are dangerous and may lead to severe injury or even death.

Gaining an adequate apprenticeship in appropriate techniques and methods of protection is important and is your own responsibility.

Users are obliged to read and understand this User Manual. Further they need to be properly equipped and instructed with the use of the necessary fall arrest equipment and emergency procedures in case of injury or sudden illness.

Users going to install AVANTI LIFT ANCHOR POINT need to be familiar with the installation section of this manual. It's essential to the safety, that the user always attach the energy absorber as high as possible above his/her position, to minimize the fall distance most possible in case of a fall.

The position of the anchor point is crucial for fall arrest – the height of the fall, elongation of lanyard and energy absorber or pendulum movement of the user should be considered in order to minimize the risk of impact in obstacles in case of a fall. It's prohibited for the user to do many modifications or use non original Avanti components when assembling AVANTI LIFT ANCHOR POINT.

Re-use of demounted AVANTI LIFT ANCHOR POINTS or parts is not allowed. Any changes or other uses beyond this manual are strictly forbidden.

Any changes or other uses beyond this manual are strictly forbidden. This documentation must be kept in the service lift for the purpose of subsequent examinations of the anchor device.

## B.2 Danger

The AVANTI LIFT ANCHOR POINT is for the use of one person only. It is strictly forbidden to carry out work if the person is in unfit mental or physical condition. Climbing and working under the influence of alcohol, drugs or any medication which can interfere with the safety are also much prohibited.

If there are any doubts to the safety of the AVANTI LIFT ANCHOR POINT, or it isn't properly fixed, deformed or damaged with cracks or similar incompatible harms it may never be used – Please contact the manufacturer immediately. In case of corrosion the anchor immediately needs to be removed.

### Observations:

Only to be used by instructed workers! Instructed workers must be aware, instructed and prepared to utilize site rescue plans.

Only to be used for preventing vertical fall!

Only to be used for fall arrest, not to hoist or hang in goods or similar! Before attaching in the ANCHOR POINT the user needs to check it is sitting fixed and screws are sitting tight and proper.

If AVANTI LIFT ANCHOR POINT has arrested a fall it may never be used again. Part must be removed from service immediately.

## B.3 Marking

Marking on Lift Anchor point plate:

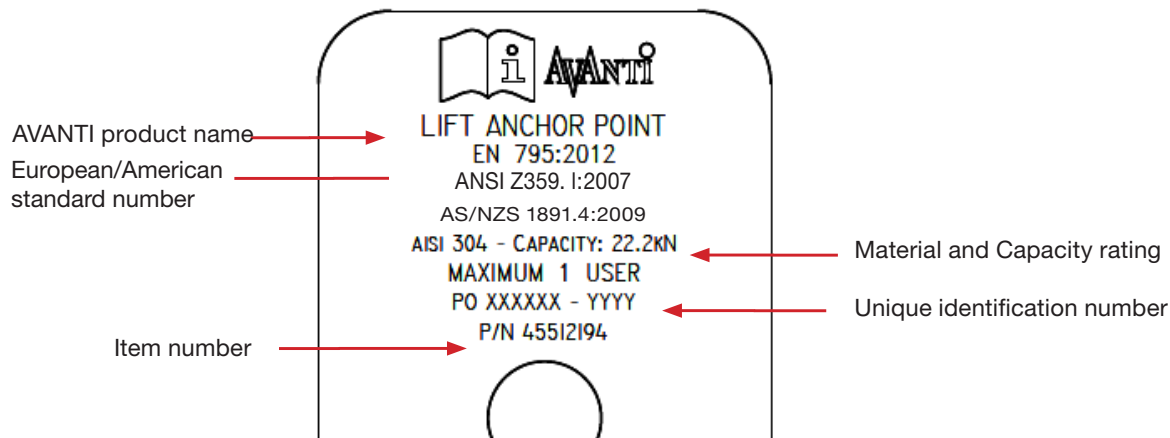

After installation, marking shall be completely accessible; otherwise additional marking near the anchor device will be necessary.

## B.4 Daily Inspection

Each time using the AVANTI LIFT ANCHOR POINT the user inspects the ANCHOR visual and manually by twisting / pulling. Check the parts are properly fixed and free of deformities, damages, cracks or similar unacceptable defects.



AT00016999 User manual Pegasus L03 bucket type (EN)  
1st Edition: 04/19  
Revision 2: 18/07/19



[avanti-online.com/contact](http://avanti-online.com/contact)

I: [www.avanti-online.com](http://www.avanti-online.com)  
E: [info@avanti-online.com](mailto:info@avanti-online.com)

